

# PUFFIN GOOD PRACTICE GUIDE



## FOREWORD

The Government's vision for transport in the future is a high quality, environmentally sustainable, reliable and safe transport system. Efficient road network operation is crucial to achieving this objective and traffic management plays an important role in managing congestion and providing a balance between the needs of all road users, especially pedestrians and cyclists. In line with this approach the Traffic Management Act 2004 imposes a duty on all local Highway Authorities to secure the expeditious movement of traffic (both vehicular and pedestrian) on their road networks.

Pedestrian crossings play an important role in encouraging walking and cycling. Signalised pedestrian and cycle facilities have been used on our roads for a number of years but the facilities and signalling sequences are not standardised and experience has shown that many people do not fully appreciate how they work leading to confusion and conflict. To improve the situation, the Department for Transport developed a new type of crossing, known as a Puffin, which can be used both at junctions and at crossings away from junctions. It will provide the basis for a standardised form of signalling at all crossings; crossings for pedestrians, cyclists and equestrians.

Puffin crossings can make more time available for pedestrians to cross when they need it, but improve network efficiency by cancelling unwanted pedestrian demands so traffic is not stopped unnecessarily. The mounting of the pedestrian signal next to pedestrians waiting to cross encourages them to look towards approaching traffic as they are waiting for the signal. Mounting in this position is also helpful for pedestrians with poor sight.

The Department and the County Surveyors' Society have developed the Puffin Good Practice Guide. The Guide provides comprehensive advice on current best practice for Puffin crossings and so helps to ensure that maximum benefits are achieved for all road users. The guidance is targeted at those involved in the whole life cycle of Puffins including advice for the decision makers involved in selecting the appropriate form of crossing and best practice guidance for designers, installers and maintainers. Advice is also included for those who arrange publicity and undertake training of school children and other vulnerable groups.

We are confident that the Guide will quickly prove an indispensable source of advice and that it will provide a significant contribution to improvements in both the safety and efficiency of the transport network.

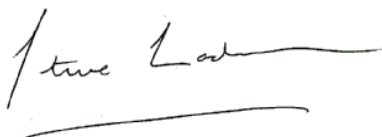

Dr Stephen Ladyman  
Minister of State for Transport  
July 2006

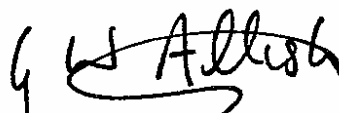

Geoff Allister  
President of the County Surveyor' Society  
July 2006

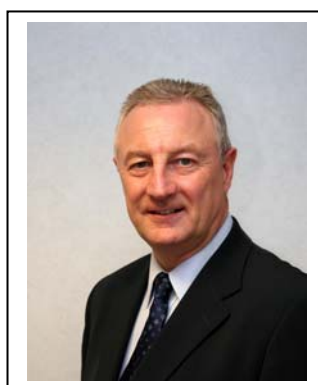

## ACKNOWLEDGEMENTS

The Puffin Good Practice Guide has been jointly funded and developed by the Department for Transport and the County Surveyors' Society and on behalf of both organisations I would like to thank all those involved in the production of this document. Particular thanks must go to the Chairman of the project Panel, Terry Carter, and also Suku Phull of the Department for Transport as well as all the other members of the panel which comprised:

Terry Carter (Chairman)	(Lancashire County Council)
Helen Gebler	(Transport for London)
Roger Hough	(Greater Manchester UTC Unit)
John Irvine	(Department for Regional Development, Northern Ireland Roads Service)
Chris King	(London Borough of Richmond)
Dave Kinnaird	(Cardiff City Council)
Suku Phull	(Department for Transport)
Bruce Slattery	(Bristol City Council)

I would also like to particularly thank KeyMed Ltd for their financial support without which making the document available electronically and free of charge would not have been possible.

Norma Sheppard of Darlington Borough Council also kindly gave permission for her work sheet for primary school children to be included for which I am grateful as I am to those who contributed photographs and other material.

Finally I would also like to thank the consultants who drafted the Puffin Good Practice Guide, the Ian Routledge Consultancy in association with Svetofor Systems and White Young Green.

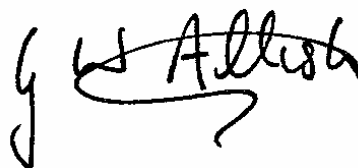

Geoff Allister  
President of the County Surveyors' Society  
April 2006

This document and a short film on using Puffin crossings are on a DVD which can be obtained free of charge from PO Box 236, Wetherby, West Yorkshire LS23 7NB. The Puffin Good Practice Guide can also be downloaded from the Department for Transport's web site (<http://www.dft.gov.uk>) and County Surveyors' Society web site (<http://www.cssnet.org.uk>). This is to encourage the widest possible circulation of the document and allow evolving experience and practice to be incorporated into updated versions of the Puffin Good Practice Guide.

© Copyright Queen's Printer and Controller of HMSO, 2006, except where otherwise stated.

This publication, excluding logos and third-party material, falls into the category of Public Sector Information. It may be reproduced free of charge in any format or medium for non-commercial research, private study or for internal circulation within an organisation. This is subject to it being reproduced accurately and not used in a misleading context. The copyright source of the material must be acknowledged and the title of the publication specified. For any other use of this material please apply for a Click-Use Licence at [www.opsi.gov.uk/click-use/index.htm](http://www.opsi.gov.uk/click-use/index.htm).

This guide was developed jointly by the County Surveyors' Society and the Department for Transport, with copyright assigned to the Controller of HMSO.

## CONTENTS

	Page
<b>1</b>	<b>INTRODUCTION</b> <b>6</b>
1.1	Scope of the Guide 6
1.2	Evolution 6
1.3	Structure of the Guide 6
<b>2</b>	<b>AN OVERVIEW OF PUFFIN FACILITIES</b> <b>7</b>
2.1	Introduction 7
2.2	The Long Term Role of Puffin Facilities 7
2.3	Background to Puffin Development 7
2.4	Puffin Operation 8
2.5	Road Safety and On-going Research 9
2.6	Business Case 9
2.7	Consistency of Use 10
2.8	Publicity and Training 10
2.9	Traffic Management Act 2004 10
2.10	Mobility 10
<b>3</b>	<b>BENEFITS OF PUFFIN FACILITIES</b> <b>11</b>
3.1	Consistency 11
3.2	Mid Block Crossings 11
3.3	Junction Traffic Signals 11
<b>4</b>	<b>GENERAL DESIGN CONSIDERATIONS</b> <b>13</b>
4.1	Introduction 13
4.2	Safety Critical Issues 13
4.3	Pedestrian Capacity 13
4.4	Pedestrian Demand Units and Pushbuttons 14
4.5	High Level Repeaters 15
4.6	Pedestrian Kerbside Detection 15
4.7	Pedestrian On-crossing Detection 16
4.8	UTC 17
4.9	Wide Crossings 17
4.10	Fine Tuning PDU Orientation 18
4.11	Converting Existing Installations 18
4.12	BV 165 18
4.13	Street Lighting 18
4.14	Maintainability 18
<b>5</b>	<b>MID BLOCK CROSSINGS</b> <b>19</b>
5.1	Pre-timed Maximum 19
5.2	MOVA 19
5.3	UTC 19
5.4	Cross Linking 19
<b>6</b>	<b>JUNCTION TRAFFIC SIGNALS</b> <b>21</b>
6.1	All Red Pedestrian Stage 21
6.2	Parallel Pedestrian Phases 21
6.3	Linking 21
<b>7</b>	<b>PDU ORIENTATION</b> <b>22</b>
7.1	Introduction 22
7.2	Central Refuge Area 22
7.3	Staggered Mid Block Crossings 23
7.4	Islands at Junction Traffic Signals 23

<b>8</b>	<b>TIMINGS</b>	<b>24</b>
8.1	Approach	24
8.2	General Timings	24
8.3	Other Timings	26
<b>9</b>	<b>INSTALLATION, COMMISSIONING, SAFETY AUDITS AND MAINTENANCE</b>	<b>28</b>
9.1	Installation	28
9.2	Commissioning	28
9.3	Safety Audits	28
9.4	Maintenance	28
<b>10</b>	<b>PUBLICITY AND TRAINING</b>	<b>29</b>
10.1	Publicity	29
10.2	Training of School Children	29
10.3	School Crossing Patrols	29
<b>11</b>	<b>EXISTING PUFFIN FACILITIES</b>	<b>30</b>
11.1	Introduction	30
11.2	Timings	30
11.3	Operational check	30
11.4	Other Problems	30
<b>12</b>	<b>CASE STUDIES</b>	<b>31</b>
12.1	Introduction	31
12.2	Puffin Operational Review	31
12.3	Conversion of Farside Pedestrian to Puffin Facilities at Junction Traffic Signals	31
12.4	Pole Installation	31
	<b>GLOSSARY</b>	<b>33</b>
	<b>APPENDICES</b>	
A	Description of Puffin Operation	34
B	Relevant Documentation	37
C	Frequently Asked Questions	39
D	Puffin Research	43
E	Traffic Signal Symbols including Puffin Symbols	46
F	Kerbside Detector Commissioning Procedures	49
G	On-Crossing Detector Commissioning Procedures	51
H	Maintenance Inspections and Operational Checks	53
I	Example Worksheet for School Children	56

# 1 INTRODUCTION

## 1.1 Scope of the Guide

The Puffin Good Practice Guide has been developed by the County Surveyors' Society (CSS) and Department for Transport (DfT). The objective is to provide guidance and examples of good practice for Puffin pedestrian facilities at junction traffic signals and mid block crossings including Toucan and equestrian crossings. The advice ranges from scheme concept development through installation, commissioning, and training to maintenance and applies to new installations as well as conversion of existing crossings to Puffin operation.

It is intended for:

- a) scheme promoters and decision makers;
- b) designers;
- c) safety auditors;
- d) installers;
- e) commissioners;
- f) maintainers;
- g) equipment suppliers; and
- h) those involved in road safety training, safe routes to schools and travel plans.



*Mid block crossing*

The Puffin Good Practice Guide is focused on Puffin issues and does not seek to replicate general advice that is covered elsewhere. Information relating to products is not included as this is best obtained from suppliers. Within the remainder of this Guide reference to 'Puffin facilities' means nearside facilities as defined in the Traffic Signs Regulations and General Directions (TSRGD) 2002 or The Zebra, Pelican and Puffin Pedestrian Crossings Regulations and General Directions 1997.

Appendix A provides, in a format that could be used as a leaflet, a description of Puffin operation

and benefits. A summary of relevant documentation is provided in Appendix B and a list of frequently asked questions is given in Appendix C.

## 1.2 Evolution

Puffin design, timings and equipment has evolved in response to user demands as well as improvements in technology including reduced angle of view pedestrian signals and smaller high level repeaters. Evolution will continue and the Guide will be updated as necessary to include the latest advice and guidance. The Highways Agency (HA) is also considering possible changes to the specification for traffic signal controllers to improve Puffin operation.

### **Puffin Initiatives**

Puffin initiatives include:

- reduced angle of view pedestrian signals;
- high level pedestrian repeater signals;
- improved mounting of detectors;
- improved responsiveness of above ground kerbside detectors;
- above ground pedestrian detectors that recognise when their alignment has changed;
- low pedestrian walking speed detectors;
- pedestrian volume detection;
- research into emerging detector systems (DfT project UG272);
- integration of Puffins into SCOOT (DfT project UG476);
- review of driver and pedestrian behaviour at MOVA controlled Puffins;
- publicity leaflet update;
- quantifying the benefits of Puffin operation (DfT project UG336); and
- accident and behavioural assessment.

## 1.3 Structure of the Guide

The remainder of the Guide is structured into two parts:

- a) Sections 2 and 3 provide a general description of Puffin operation and benefits; and
- b) the remainder of the document provides design, installation, operation and maintenance guidance as well as case studies and requirements for publicity and training.

## 2 AN OVERVIEW OF PUFFIN FACILITIES

### 2.1 Introduction

This section provides a general introduction to Puffin facilities:

- a) setting out the DfT's longer term intention for Puffins;
- b) outlining the background of Puffin development;
- c) describing Puffin operation;
- d) discussing the road safety case;
- e) setting out the business case for Puffins;
- f) highlighting the need for consistent use of Puffin facilities;
- g) describing publicity and training requirements;
- h) outlining the potential to assist meeting Traffic Management Act requirements; and
- i) highlighting the potential to use Puffins to improve mobility.



*View of a junction Puffin*

### 2.2 The Long Term Role of Puffin Facilities

It is the (DfT's) intention that Puffin pedestrian facilities will become the standard form of provision of signalled pedestrian crossings. This will provide a consistent approach at junction traffic signal and mid block crossings (including Toucans and equestrian crossings) as well as operational benefits for all road users.

Local authorities should therefore be planning migration to Puffin style facilities particularly for new works and refurbishment/upgrades.

### 2.3 Background to Puffin Development

The first formal publication relating to Puffin crossings was in the Department of Transport Network Management and Driver Information Division specification 'Requirements for a New

Pedestrian Crossings Strategy (Puffin)' published in August 1992. This specification gave detailed information on functional aspects of the equipment to be used but little in the way of advice on design and layout.

In March 1993 the DoT issued a Network Management Advisory Leaflet 'The Use of Puffin Pedestrian Crossings'. This gave information on differences between Pelican and Puffin strategies and some information on their use at mid block crossings. The use of Puffin crossings, however, still required specific approval on a site by site basis until The Zebra, Pelican and Puffin Pedestrian Crossing Regulations 1997, came into force. This allowed Puffin facilities to be installed at mid block crossings but use of Puffins at junction traffic signals was not permitted without authorisation until the 2002 Traffic Signs Regulations and General Directions were published. Various Traffic Advisory Leaflets (TALs) have also been issued:

- a) TAL 1/01 'Puffin Pedestrian Crossings'. This describes the Puffin strategy and identifies the potential benefits;
- b) TAL 1/02 'The Installation of Puffin Pedestrian Crossings'. This gives specific advice on equipment and general installation requirements together with 'model' layouts and guidance on appropriate timings for the various periods; and
- c) TAL 5/05 'Pedestrian Facilities at Signal Controlled Junctions'. This provides further guidance on the use of Puffin facilities within traffic signal junctions including timings and model layouts.

A summary of relevant current documentation is given in Appendix B.

#### **Puffin Roll Out Strategy**

A Puffin roll out strategy could include:

- all new works or refurbishment/upgrades to incorporate Puffin facilities;
- a radial/area wide approach to minimise risk of confusing pedestrians;
- targeting junction traffic signals with congestion problems that Puffin facilities could help reduce; and
- an education, training and publicity strategy developed and implemented.

## 2.4 Puffin Operation

Puffin pedestrian facilities have been developed to provide improved operation for pedestrians and to reduce delay for both drivers and pedestrians. This is achieved by:

- a) using positive and unambiguous nearside pedestrian displays;
- b) providing consistent displays to drivers;
- c) cancelling pedestrian demands when pedestrians cross in gaps; and
- d) varying the clearance time after the pedestrian green signal to allow slow pedestrians to cross without harassment from drivers.

Puffin facilities can be implemented at both traffic signal junctions and mid block crossings (pedestrian only, Toucan and equestrian) and irrespective of the control strategy used, e.g. vehicle actuated, MOVA, UTC etc.



*Puffin Style  
Toucan*

### **Pedestrian Displays**

Prior to the introduction of Puffin facilities, pedestrian signals at mid block crossings and junction traffic signals were located on the farside of the crossing. With Puffin facilities nearside pedestrian displays are used and pedestrians are presented with a steady red or a steady green signal.

Potential pedestrian confusion is reduced because:

- a) the flashing green pedestrian sequence at Pelican crossings is no longer used; and
- b) blackouts are not used (the only exception to this is when there are central refuge areas at straight across crossings (see Section 7.2)).

With farside pedestrian signals, pedestrians have to look away from approaching traffic to see the pedestrian signal. When pedestrians look at a nearside Puffin pedestrian display they are also

aware of approaching traffic. Seeing the approaching traffic and the pedestrian display at the same time should help to reduce accident risk.

Pedestrians with sight impairments (and it is estimated up to two million pedestrians fall into this category) also should find it easier to see a nearside pedestrian display compared to the farside pedestrian signal.



*PDU in foreground with approaching traffic in the background*

### **Driver Displays**

The flashing amber sequence used at Pelican crossings can encourage aggressive driver behaviour. With Puffin facilities this problem is minimised because a steady red signal, similar to traffic displays at junction traffic signals, is displayed to drivers when pedestrians are crossing.

Consistency of driver displays at mid block crossings and junction traffic signals will also reduce the risk of driver confusion.

### **Cancelling Pedestrian Demands**

At non-Puffin facilities when a pedestrian demand is entered the pedestrian phase must run even if the pedestrian has crossed in gaps in traffic. At Puffins, kerbside detection is used to monitor when pedestrians are present and cancel demands when pedestrians cross in gaps in traffic. This will help to alleviate driver frustration caused by unnecessary delays.

### **Variable Clearance Times**

At Pelicans and junction traffic signals with farside pedestrian facilities, the clearance time after the pedestrian green is fixed. On-crossing detection is used at Puffin facilities to vary the pedestrian clearance times between defined minimum and maximum time:

- a) when slow moving pedestrians are crossing, the clearance time is extended to provide pedestrians with the time they need to cross; but
- b) when there are no pedestrians on the crossing, the clearance time is minimised.

The average clearance time at Puffins can be reduced compared to the fixed clearance when farside pedestrian facilities are used.

## 2.5 Road Safety and On-going Research

It is believed that accidents should reduce as a result of the introduction of Puffin facilities but there is currently insufficient accident data available to verify this. Some research has been undertaken into the safety aspects of Puffin facilities, particularly at mid block crossings, but the results are somewhat contradictory and in some cases influenced by poor installation standards.

A summary of Puffin related research work, some of which is on-going, is provided in Appendix D.

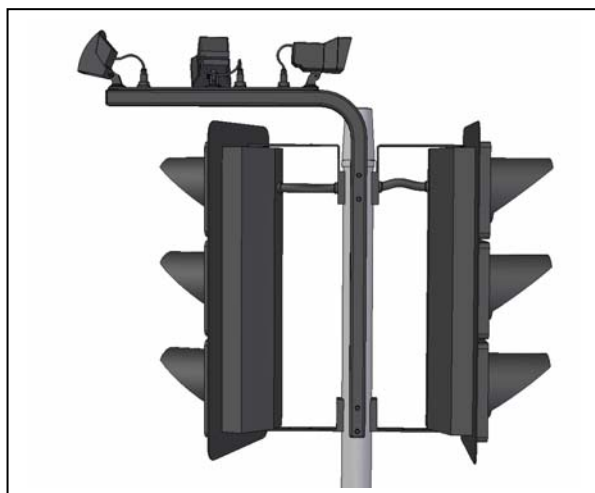

*Integrated detection mounting bracket*

## 2.6 Business Case

Whilst Puffin facilities offer benefits, there will be some increased capital and maintenance costs, mainly as a result of the provision of pedestrian detection. At mid block crossings additional costs are less significant.

A business case for use of Puffin facilities can be established for junction traffic signals by assessing the potential saving in vehicle and pedestrian delay.

The business case for mid block crossings is more subjective but can be justified by the benefits for

### Quantifying Puffin Benefits at Junction Traffic Signals

The benefits of Puffin facilities can be assessed using LINSIG or other models for junction traffic signals with a full all-red pedestrian stage:

- a base case model is prepared using traditional fixed clearances and a staging based on the assumption that the pedestrian stage appears every cycle. Delays are assessed;
- the model is then run taking account of the benefit of Puffin facilities:
  - reduced appearance of pedestrian stages, e.g. with cancelling of pedestrian demands the pedestrian stage may only appear every second or third cycle;
  - reduced clearance time, e.g. the average pedestrian clearance times could be reduced to reflect the use of on-crossing pedestrian detection;
  - reduced pedestrian green time; and
- the reduction in pedestrian and vehicle delays can be assessed by comparing the outputs of the two models and, if required, an annual cost saving estimated.

pedestrians in terms of improved ‘comfort’ achievable without increase in vehicle delay. At some mid block crossings, cancelling unnecessary pedestrian demands could significantly reduce vehicle delays and this can be quantified.

The effect on the accident rates at mid block crossings and junction traffic signals will be quantified in the longer term and could then be used in the business case.

### Business Case for Puffin Facilities at Junction Traffic Signals

Research has shown (UG336) that when two existing junction traffic signals were converted from farside pedestrian facilities to Puffin with kerbside and on-crossing detection the average annual rate of return was 325 percent.

This was based on reductions in traffic delay on the main roads only and took no account of reductions in pedestrian and side road traffic delays.

## 2.7 Consistency of Use

Consideration should always be given to the type of pedestrian facilities at adjacent mid block crossings or junction traffic signals. If, for example two or more traffic signals are close to each other, say within 100 metres, one with nearside Puffin displays and the other with traditional farside signals, there is a risk that pedestrians may become confused with a resulting increase in accident risk. The adjacent facility should then be converted to utilise Puffin facilities if reasonably practicable.

### Consistency

Implementing Puffin facilities on an area or route basis will:

- minimise the risk of confusing pedestrians; and
- also make publicity easier.

## 2.8 Publicity and Training

When Puffins are introduced, especially the first few facilities in an area of a town or city, publicity should be issued. The DfT intends to review the existing 'How to Use a Puffin' leaflet and produce accompanying posters. It is inevitable that there will be a mixture of pedestrian control strategies on-street during the transition process to full Puffin implementation and publicity should take this into account.

Training of school children is important and should be provided when Puffin facilities are introduced. Provision of information to other users, including adults and vulnerable groups, should also be provided when appropriate.



*High level repeaters*

## 2.9 Traffic Management Act 2004

Part 2 of the Traffic Management Act 2004 imposes a duty on all local authorities to secure the expeditious movement of vehicular and pedestrian traffic on their road networks. The efficiency benefits offered by Puffin facilities, particularly at junction traffic signals, can assist Local Authorities to meet this objective.



*Bilingual push button*

## 2.10 Mobility

Puffin facilities improve mobility for many pedestrian groups including disabled and older people as well as mothers with young children.

LTP guidance highlights mobility and accessibility issues. Funding for conversion of existing facilities to Puffins to support Disability Discrimination Act (DDA) requirements could therefore be sought through the LTP process.

The Disability Discrimination Act 2005, which comes into effect in December 2006, places new duties on public authorities to have due regard to the need to take steps to take account of disabled persons' disabilities, even where that involves treating disabled persons more favourably than other persons.

### 3 BENEFITS OF PUFFIN FACILITIES

#### 3.1 Consistency

At the present time at mid block crossings, drivers may be presented with standard junction traffic signal displays or with flashing amber signals at Pelicans. Puffin facilities will provide consistent displays to drivers at all crossing types.

Pedestrians and cyclists may encounter:

- a) nearside or farside pedestrian signals;
- b) steady or flashing green signals;
- c) pedestrian signals with or without blackouts; and
- d) pedestrian green signals changing to a blackout or red when they are in mid crossing.

Puffin facilities will provide a consistent display to pedestrians at mid block crossings and junction traffic signals using steady red and green signals. Blackouts would only be used when necessary at splitter islands.

#### 3.2 Mid Block Crossings

The major benefit of the use of Puffin facilities at mid block crossings is the elimination of the flashing green pedestrian signal and the flashing amber signal to drivers. This should reduce confusion and accident risk. Research at mid block crossings in Chester, London and Southampton has shown that pedestrians were significantly less likely to cross against a steady red signal (at Puffins) compared to a flashing green signal (at Pelicans).

The variable clearance time benefits slow moving pedestrians when required but, when pedestrians are not present on the crossing, the clearance time will be minimised.

##### **Variable Clearance Times at Mid Block Crossings**

DfT research in Chester and Southampton (UG336) has shown that vehicle delay at sites converted from Pelicans to Puffins is broadly unchanged.

The variable clearance time maintains the efficiency of the flashing amber period but this is achieved in a manner that provides drivers and pedestrians with positive and unambiguous signals and the likelihood of aggressive driving is reduced.

##### **Puffin Facilities at Mid Block Crossings**

Conversion of Pelican to Puffin crossings will:

- simplify displays to pedestrians and drivers;
- assist slow moving pedestrians to cross in safety; and
- have little impact on or reduce traffic delays.

Kerbside detection can be very useful in cancelling unnecessary pedestrian demands but if, however, there is likely to be an immediate change to the pedestrian stage when the pushbutton is pressed, there is little benefit in installing this detection.

#### 3.3 Junction Traffic Signals

Puffin facilities at junction traffic signals can provide significant operational improvements. This results from the use of variable pedestrian clearance times, cancelling of unnecessary pedestrian demands and reduced pedestrian green times. Pedestrian confusion will also be minimised by the reduced use of blackouts.

##### *Variable Pedestrian Clearance*

At junction traffic signals with traditional farside pedestrian facilities a fixed clearance period follows the pedestrian green. With Puffin facilities there is a variable clearance period and typically this would be significantly less than the equivalent fixed clearance period. When necessary, clearance times will extend to accommodate slow moving pedestrians or high pedestrian volumes. If, however, pedestrians clear the crossing during the pedestrian green

##### **Improved Efficiency at Junction Signals**

DfT research in the UK (UG336) has shown that when junction traffic signals with an all red pedestrian stage are converted from farside to Puffin pedestrian facilities, the average lost time can be reduced significantly. This is a result of the reduced average clearance time and the shorter pedestrian green signal.

Cancelling of unnecessary demands when pedestrians cross in gaps can also significantly reduce cycle times and thus further reduce delay for all road users.

signal, the clearance will run to a minimum. The reduced clearance time can be modelled and the impact on capacity assessed.

#### **Puffin facilities at Junction Traffic Signals**

Compared to farside pedestrian facilities at junction traffic signals, Puffin facilities will:

- simplify displays to pedestrians;
- assist slow moving pedestrians to cross in safety;
- typically reduce traffic delays; and
- typically reduce pedestrian delays.

#### ***Cancelling Pedestrian Demands***

At junction traffic signals with traditional farside pedestrian facilities, when pedestrians press the pushbutton the demand is only cleared by the appropriate pedestrian green running. This can create unnecessary delay, particularly with all red pedestrian stages, if pedestrians do not wait for the pedestrian green signal. This can lead to driver frustration and increased accident risk.

When Puffin pedestrian facilities are utilised demands can be cancelled if pedestrians cross in gaps. With very high traffic flows or very high pedestrian flows the opportunity to cancel demands may be limited, there are, however, many sites where cancelling pedestrian demands will have a significant impact on capacity. At sites where opportunities to cancel pedestrian demands at peak times are limited, there can be significant benefits at other times, particularly either side of the peak periods.

The reduced appearance of pedestrian stages can be modelled and the impact on capacity assessed.

#### **Cancelling Pedestrian Demands**

DfT research in the UK (UG336) has shown that when kerbside detection was used at a signalised crossroads with an all red pedestrian stage, 32 percent of pedestrian demands were cancelled (Section 12 provides more detail).

#### ***Pedestrian Green Signal***

The pedestrian green signal at Puffin facilities is generally shorter than at comparable width crossings with farside pedestrian facilities, particularly at wider crossings. The variable

clearance period at Puffin facilities ensures pedestrians receive the necessary time to cross the carriageway.



*Puffin crossing at junction traffic signals*

## 4 GENERAL DESIGN CONSIDERATIONS

### 4.1 Introduction

This section considers general design issues for mid block crossings and junction traffic signals:

- a) safety critical issues;
- b) pedestrian capacity;
- c) pedestrian demand units and pushbuttons;
- d) high level repeaters;
- e) pedestrian kerbside detection;
- f) pedestrian on-crossing detection;
- g) UTC;
- h) wide crossings;
- i) street lighting; and
- j) maintainability.

A summary of relevant documentation is provided in Appendix B, a list of frequently asked questions is given in Appendix C and Appendix E provides traffic signal symbols including the DfT's proposed Puffin symbols.



*Combined PDU*

### 4.2 Safety Critical Issues

As with other forms of traffic control, the basic operation of Puffin pedestrian facilities has specific safety critical aspects:

- a) if pedestrian demands were to be cancelled when pedestrians remain present, pedestrians would be forced to cross without the benefit of a green signal;
- b) if pedestrians were not established on the crossing at the end of the pedestrian green signal (i.e. picked up by the on-crossing detection), this could result in pedestrians being stranded on the crossing when vehicles regained right of way; and
- c) if the variable clearance period failed to extend, pedestrians could be stranded on the crossing when vehicles regained right of way.

Those responsible for design, commissioning and on-going maintenance activities should always be aware of these safety critical issues to ensure the safety of Puffin operation.

### 4.3 Pedestrian Capacity

As with any controlled pedestrian facility, consideration should be given to the volume of pedestrians wishing to use the crossing. The width of the crossing (between the studs) is critical and simple calculations can be undertaken to assess pedestrian capacity. The duration of the pedestrian green signal may be increased when pedestrian flows are high and this can also be built into the calculations together with estimates of pedestrian clearance times.

#### Assessing Pedestrian Capacity

One way of assessing pedestrian capacity of a crossing is as follows:

- determine the number of pedestrians that can stand on the footway parallel to the kerb between the crossing studs allowing 600mm per pedestrian (adjust as required);
- assess the number of parallel rows of pedestrians that could wait on the footway allowing 600mm per row (adjust as required);
- determine the volume of pedestrians that could enter the crossing in the pedestrian green assuming one row enters every two seconds;
- calculate the number of cycles per hour and hence the total possible hourly one way pedestrian capacity;
- if the pedestrian flow is predominantly in one direction the one way pedestrian capacity can be assumed. If the flows are more balanced, pedestrians will interact as they cross and the total capacity will be reduced to say 40 percent of the one way flow in each direction; and
- if necessary for expected or predicted pedestrian arrival rates, capacity can be increased by widening the crossing, making the pedestrian green signal longer or adjusting the traffic timings so that the cycle time is reduced and the pedestrian facility appears more often.



*Puffin  
pushbutton*

#### 4.4 Pedestrian Demand Units and Pushbuttons

Pedestrian displays comprise pedestrian demand units (PDUs) and pushbuttons (PBs). Pedestrian demand units include pedestrian red and green displays plus a pushbutton either in combined or separate units. Pushbuttons do not include any pedestrian displays other than an indication that a demand had been entered. Rotating cones should always be provided in the right hand PDU/PB but some authorities provide them in all PDUs/PBs.

PDUs should be located between waiting pedestrians and the nearest approaching traffic as this encourages pedestrians to look towards the approaching vehicles. If a PDU is not located to the right (when viewed looking into the crossing), a PB should be provided as partially-sighted individuals, and those with guide-dogs are trained to always seek a PB on the right. Reduced height poles may be used to carry a PDU or PB only but note that poles carrying PDUs have to be slightly longer than the standard short pole used with PBs.

DfT advice recommends PDUs and PBs should be installed on poles:

- not more than 500mm from the line of crossing studs so that pedestrians standing on the tactile paving, particularly those with sight problems, can reach the PDU; and
- inclined at 25 to 30 degrees to the kerb face pointing into the footway (except on islands).

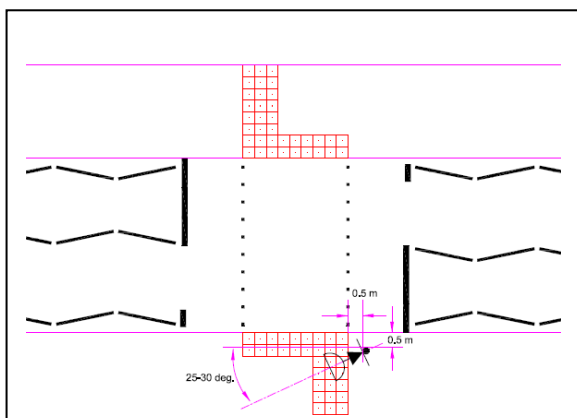

*Pole location relative to kerb and stopline*

#### Audible Devices

Audible devices and ‘bleep and sweep’ indicate to pedestrians when it is safe to cross. Audible devices should only be used at straight across mid block crossings or at junction traffic signals when an all red pedestrian stage is utilised. ‘Bleep and sweep’ may be used at staggered mid block crossings.

Audible devices should not be used:

- at staggered mid block crossings;
- at junction traffic signals with parallel pedestrian phases;
- at junction traffic signals with an all red pedestrian stage if all pedestrian phases are not running in the stage; or
- at junction traffic signals and/or mid block crossings in close proximity.

DfT guidance is to set PDUs and PBs on poles with a minimum of 500mm clearance from the kerb face but some authorities provide a second (usually short) pole and PB on the left hand side of the crossing set back 800mm from the kerb face to assist motorised pedestrians and wheelchair users. There can be problems locating the pole in the correct position and setting the pole with up to 600mm clearance works well in practice. Some authorities are concerned that setting the poles with only 500mm clearance places pedestrians at risk from passing vehicles but in practice the angle of the PDU/PB encourages pedestrians to stand slightly further back.

In some circumstances, for example where there are utility problems, it may be necessary to site poles more than 500mm from the kerb face to avoid existing services. In such cases, the angle of the PDU may have to be reduced to ensure that pedestrians do not stand too far from the kerb edge.



*PDU at  
the back of a  
narrow footway*

When footways are narrow (so that installation of poles would reduce the clearance between the pole and the back of footway to less than 1.2 metres) or if there are utility problems, poles should be mounted at the back of the footway and the PDU and pushbutton installed pointing slightly into the footway (narrow field of view PDUs may be useful to prevent see-through). If possible, locally widen the footway using a 'buildout' to avoid locating poles at the back of the footway.

#### See-Through

See-through of red and green pedestrian displays can be an issue, particularly at junction traffic signals with parallel pedestrian phases and triangular islands. PDUs with reduced viewing angle are now available and these will help to reduce see-through problems.

#### 4.5 High Level Repeaters

When pedestrian flows are high, standard height PDUs can be masked by waiting pedestrians. High level repeaters can be installed using the red/green display repeaters with a minimum 1.70 metres clearance to the underside of the unit. Reduced size high level repeaters are also being developed. When reduced angle of PDUs are used the high level repeater should also be reduced angle of view.

#### Mixing Displays

Farside and nearside pedestrian displays should never be mixed at the same installation as this could confuse pedestrians and increase accident risk.

Ideally installations in close proximity should also have the same type of pedestrian facility to avoid possible confusion.

#### 4.6 Pedestrian Kerbside Detection

It is essential that kerbside pedestrian detection holds the demand when pedestrians are present but cancels the demand if all waiting pedestrians cross in gaps. Kerbside detection using different technologies may be installed in-ground or above ground. Care should be taken to ensure sufficient detectors are used to cover the full pedestrian waiting area. Detailed information should be sought from suppliers on the size of the detection zone of their detectors so that the number of detectors required may be calculated.



*Smaller high level repeater under trial*

The areas where pedestrians wait should be identified by observation but typically should extend from the pole carrying the PDU to the remote line of crossing studs plus 500mm and for a width of 1.2m from the kerb. On high speed roads pedestrians tend to keep further back from the kerb and this should be taken into account when defining the pedestrian waiting area. If ponding occurs at or close to pedestrian crossings, pedestrians may stand further back from the kerb and this should be taken into account until drainage problems are addressed.

A pedestrian demand will not be accepted by the controller unless the associated kerbside detector

#### Omitting Pedestrian Kerbside Detection

Pedestrian kerbside detection may be omitted at mid block crossings when there are likely to be few opportunities to cancel demands, for example if:

- there is high probability of an immediate change to the pedestrian signal, e.g. pre-timed maximum is used; or
- pedestrian flows are very high; or
- traffic flows are very high.

At junction traffic signals, pedestrian kerbside detection may be omitted when pedestrian flows are very high or pedestrian phases run in parallel with a major traffic movement as unnecessary appearance of parallel pedestrian phases would not reduce capacity.

The peak and off peak situation should be taken into account when considering omitting pedestrian kerbside detection because substantial benefits can be achieved outside of peak periods.

is active when the PB is pressed. When kerbside detection fails it provides an output equivalent to a pedestrian being present. An incorrectly aligned kerbside detector will prevent demands being accepted until the DFM (detector fault monitor) times out. If, however, the detector is very badly aligned and detects traffic movement the DFM will not time out.



*Pedestrian detection*

#### 4.7 Pedestrian On-crossing Detection

On-crossing detection extends the variable clearance period between defined minimum and maximum values. DfT research has shown (UG336) that typically the average value of the clearance time at Puffin facilities will be significantly reduced compared to the fixed clearance time.

Generally when two on-crossing detectors are used on a crossing they should be arranged diagonally and set up to view the opposite side of the carriageway but detectors are evolving rapidly. Care must be taken to ensure adequate numbers of detectors are used to provide coverage

##### **Faulty On-Crossing Detectors**

If on-crossing detectors do not go active between the end of the previous pedestrian green until the start of the minimum all red period after the current pedestrian green, the controller deems the detector to be faulty and the associated variable clearance would be extended to the maximum. In these circumstances special conditioning could be used to limit the maximum clearance to  $[L/1.2]$  seconds, i.e. the pedestrian Comfort Time defaults to zero.

Note if an on-crossing detector was misaligned but still detected moving vehicles or pedestrians, the controller would not deem the detector to be faulty.

##### **Safety Feature**

To ensure that a pedestrian demand will always be accepted by a controller, even if the associated kerbside detector (if fitted) is inactive when the PB is pressed, configure the controller so that:

- a pedestrian demand without the associated kerbside detector active will be accepted but latched (cannot be cancelled); but
- if a pedestrian demand is input when the associated kerbside detector is active, the demand will be unlatched (may be cancelled).

of the whole pedestrian crossing area, particularly with longer crossings. If pedestrians cross outside of the crossing area, as defined by the studs, then they will not extend the clearance period and the controller will revert to traffic green. If this is likely to be a significant issue appropriate measures should be taken to encourage pedestrians to remain on the crossing e.g. short sections of guard rail, planters etc. In addition to extending the variable clearance period, on-crossing detectors should be set up:

- a) to ensure that pedestrians are established on the crossing and picked up by the on-crossing detectors if they enter at the end of the pedestrian green. The minimum clearance period will assist but it is essential to ensure the on-crossing detection is set up to detect pedestrians as soon as they enter the carriageway. Some detectors are slower to respond to pedestrians entering the crossing than leaving; but
- b) should not extend the variable clearance period once pedestrians clear the crossing.

The average walking speed of 85 percent of pedestrians is 1.2 metres/second or greater but current on-crossing detectors will detect pedestrians at walking speeds as low as 0.5 metres/second. Detectors capable of detecting

##### **Above Ground Detection**

To operate effectively:

- kerbside detectors require a clear view of the entire pedestrian waiting area. Installing above ground detectors directly above the PDU and PB will assist; and
- on-crossing detection requires a clear view of the crossing area.

pedestrians at very low walking speeds are now coming onto the market and should be used when appropriate. Careful consideration needs to be given to clearance times when very slow pedestrians are anticipated.

If pedestrian on-crossing detection extends unnecessarily apart from increasing vehicle delay it can confuse pedestrians who arrive after the pedestrian green signal finishes and are unsure whether to enter the carriageway or wait. This uncertainty may increase accident risk.

#### **Omitting Pedestrian On-crossing Detection**

Pedestrian on-crossing detection should not be omitted at mid block crossings as it ensures that pedestrians clear the crossings before traffic regains right of way.

At junction traffic signals, pedestrian on crossing detection may be omitted for parallel pedestrian phases or if crossings are very short, say less than six metres wide. When on-crossing detection is omitted a fixed clearance period will be required. It should be noted:

- when on-crossing detection is used, the minimum clearance can be as low as two seconds; but
- a six metre wide crossing without on-crossing detection will require a fixed clearance of eight seconds (assuming a pedestrian comfort time of three seconds) or five seconds if the pedestrian comfort time is set to zero.

Unnecessarily long clearances will reduce capacity and increase traffic delay.

#### **4.8 UTC**

UTC generally seeks to minimise vehicle delay across a network and Puffin facilities will support UTC by cancelling demands if pedestrians cross in gaps and by varying the clearance period. The TRL has now modified the SCOOT kernel to maximise the operational benefits resulting from variable clearance times. The new logic is available in SCOOT version MC3 which was released in Autumn 2005.

UTC cycle times can, however, result in increased pedestrian delay, especially at mid block crossings and these crossings should be carefully set up to avoid unnecessary delay. Pedestrians regularly

crossing in gaps when a crossing is under UTC control may indicate that the network configuration is constraining the operation of the crossing to an unreasonable degree.



*A wide crossing*

#### **4.9 Wide Crossings**

Wide crossings are used when pedestrian flows are very high and additional kerbside and on-crossing detectors will therefore be required to ensure that the full pedestrian waiting area and crossing areas are fully covered.

High level repeaters should be used to increase pedestrian view of the red/green signals. Additional pole mounted PDUs and high level repeaters should also be provided to ensure that pedestrians have a clear view of at least one pedestrian red/green display.

#### **Mid Block Crossings on Wide Roads**

LTN2/95 states that when a road is more than 15 metres wide a staggered layout should be provided but if the road width is between 11 and 15 metres a staggered layout should be considered. For road widths in the range of 11 to 15 metres, if a staggered crossing is not used central refuges are often provided to house traffic signal heads.

Pedestrians often experience difficulty in establishing right of way in the second half of crossings at Pelicans with central refuges because of driver behaviour during the flashing amber sequence.

Puffin facilities will assist pedestrians by holding traffic on red until the crossing is cleared. The variable all red will however ensure that vehicle delay is minimised.

#### 4.10 Fine Tuning PDU Orientation

Fine tuning of PDU orientation is often required after installation. This can be achieved by:

- a) using poles installed in preformed foundations that allow the pole to be rotated; or
- b) using PDUs that allow some lateral adjustment after fixing to the pole.



*Children crossing at junction traffic signals*

#### 4.11 Converting Existing Installations

When converting existing installations it is essential to ensure that the installations are to an acceptable operational standard. Experience has shown that if Puffin facilities are added to sub-standard existing installations accident rates may increase.

#### 4.12 BV 165

Many aspects covered in this section have implications for BV 165 assessment. Satisfying the requirements laid down in this Guide will also generally satisfy BV165 assessment requirements.



*Cranked pole*

#### 4.13 Street Lighting

Street lighting at Puffin facilities should meet specified requirements for road safety reasons. In addition, adequate street lighting will ensure the most effective operation of 'image based' pedestrian detectors.

Puffin crossings should be lit to at least one of the following:

- a) BS5489-1:2003 Code of Practice for the Design of Road Lighting (BSI);
- b) CEN/TR 13201-1:2004 Road Lighting (BSI); or
- c) TR 12 1997 Lighting of Pedestrian Crossings (ILE).

Care should be taken to ensure that trees, shop awnings etc do not reduce overall lighting levels or create localised low lighting areas that may impair pedestrian kerbside detector operation.



*Secondary head obscured by foliage*

#### 4.14 Maintainability

Designers should always take into account maintainability of installations, particularly in relation to above ground pedestrian and vehicle detection.

## 5 MID BLOCK CROSSINGS

### 5.1 Pre-timed Maximum

With vehicle actuated operation the traffic green maximum timer starts when a pedestrian demand is entered, thus, when traffic flows are high the vehicle green can be extended to the maximum which can result in significant pedestrian delay.

The pre-timed maximum facility starts the traffic green maximum timer when traffic regains right of way, rather than when a pedestrian demand is entered. It should be noted:

- a) if the pre-timed maximum had expired before the next pedestrian demand was entered there would be an immediate change to pedestrian green. To reduce accident risk, some authorities introduce a slight delay before an immediate change to pedestrian green to allow drivers of approaching vehicles the time to realise that pedestrians are at the crossing. This delay is set in the controller using standard timing options; and
- b) if the pre-timed maximum had not expired before the next pedestrian demand was entered the remainder of the pre-timed maximum period could run if there were traffic extensions.

The selection of the value of the maximum green time is important with pre-timed maximum and should take into account traffic flows, number of pedestrians, site conditions, etc.

The pre-timed maximum facility is only applicable if the road speed limit does not exceed 30mph and the crossing is not subject to UTC control. For many authorities, pre-timed maximum is used as standard on this type of road.



*Wide mid block crossing*

### 5.2 MOVA

Whilst MOVA may be potentially more efficient than vehicle activation at mid block crossings on low speed roads, many authorities are not yet certain of the benefits of MOVA and do not believe the additional complexities, cost and maintenance implications are justified. This may, however, change as a result of the development of MOVA 5 (Compact MOVA) that allows MOVA 'In' loops to be omitted.

At mid block crossings on high speed roads (i.e. an 85 percentile speed in excess of 35 mph) MOVA potentially offers a more efficient solution than speed assessment or speed discrimination.

### 5.3 UTC

Some authorities attempt to minimise the impact of UTC on pedestrian delays at mid block crossings by:

- a) increasing the length of the pedestrian window presented by the UTC system;
- b) dropping UTC control when traffic flows are light and allowing the crossing to run in vehicle activated mode with or without or pre-timed maximum; or
- c) omitting mid block crossings from UTC control unless it is essential to maintain coordination.

Another option would be to treat a mid block Puffin as a two stage traffic signal junction with demand dependency and gapping out when under UTC control.

### 5.4 Cross Linking

To minimise pedestrian delays at staggered Pelicans it is not uncommon for pedestrian demands to be forwarded from one stream to the other. If this is implemented at staggered Puffin crossings with kerbside pedestrian detection, care should be taken to ensure the demand is not cancelled before pedestrians reach the waiting area or that the pedestrian signal appears unnecessarily.

## PRE-TIMED MAXIMUM

### Vehicle Actuated Operation

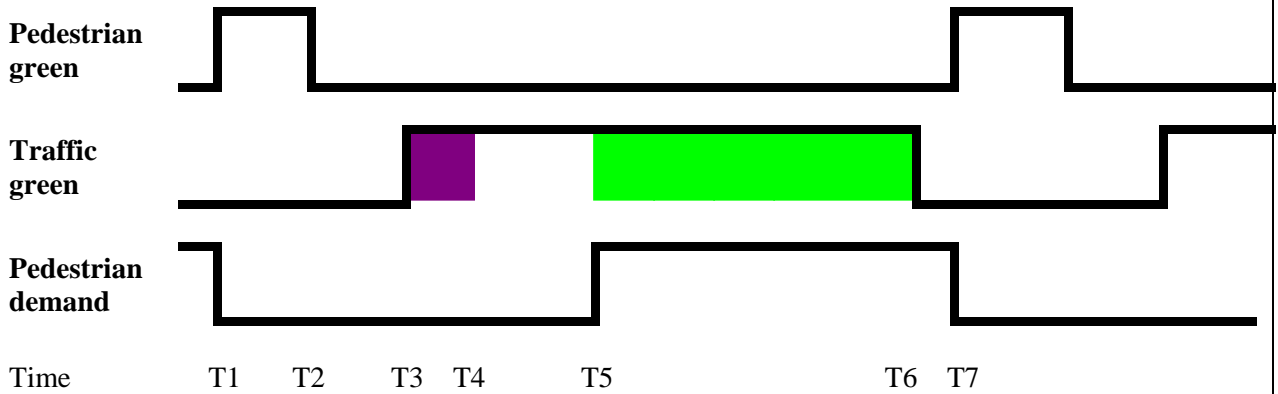

**T1:** Pedestrian green starts;

**T2:** Pedestrian green ends;

**T3:** Traffic green commences and minimum traffic green timer starts;

**T4:** Minimum traffic green times off;

**T5:** Pedestrian demand entered and maximum traffic green timer starts;

**T6:** Maximum green timer reaches maximum (assuming traffic extensions) and traffic green ends; and

**T7:** Pedestrian green starts.

### Vehicle Actuated Operation with Pre-timed Maximum

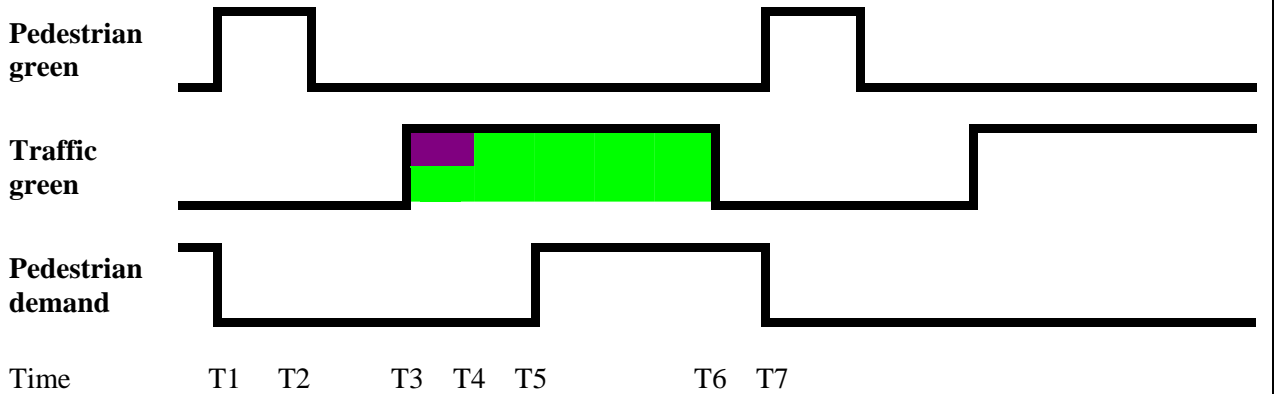

**T1:** Pedestrian green starts;

**T2:** Pedestrian green ends;

**T3:** Traffic green commences and minimum **and maximum** traffic green timers start;

**T4:** Minimum traffic green times off;

**T5:** Pedestrian demand entered;

**T6:** Maximum green timer reaches maximum (assuming traffic extensions) and traffic green ends; and

**T7:** Pedestrian green starts.

## 6 JUNCTION TRAFFIC SIGNALS

### 6.1 All Red Pedestrian Stage

When using an all red pedestrian stage, every pedestrian crossing should have a separate phase. When a PB demand occurs, only the pedestrian demand indicators for the demanded phase should illuminate. If one approach has very low traffic and pedestrian flows, there is a risk the controller will run the clearance period to a maximum if any on-crossing detectors are deemed to be faulty. The impact of this can be minimised by:

- a) specifying pedestrian phases to only appear when demanded; and/or
- b) configuring the controller such that the maximum clearance as a result of on-crossing detectors deemed to be faulty is  $[L/1.2]$  seconds not  $[L/1.2 + Pc]$ .

Note audible devices should only operate if all the pedestrian phases in an all red pedestrian stage appear.

### 6.2 Parallel Pedestrian Phases

Puffin type pedestrian phases that run in parallel with vehicle phases at junction traffic signals can be configured to appear and terminate in different ways depending on traffic and pedestrian flows and local practice.

If pedestrian phases always appear regardless of demand they can run:

- a) for the duration of the associated traffic phase then shut down. If the carriageway is wide there is a risk there will be a long clearance period after the pedestrian green but (assuming on-crossing detection was installed), if no pedestrians were on the crossing there would only be a short all red; and
- b) for a minimum then shut down. This ensures, particularly with higher pedestrian flows, that long clearances after the pedestrian green do not increase traffic delay. If, however, other pedestrians arrive after the pedestrian green has ended (but the associated traffic phase is still running) and press the pushbutton the controller may not respond (unless appropriate conditioning has been implemented).

Alternatively the parallel pedestrian phase may appear only if demanded:

- a) at the start of the stage. The pedestrian green could then terminate after a minimum or run as long as the associated traffic phase as described above;
- b) at any point in the stage. The pedestrian green would then run until the associated traffic phase terminates. If called just before the associated traffic green terminates, there is a risk of extending the stage until the minimum pedestrian green expires and the clearance runs; and
- c) during a window time measured from the start of the stage. The pedestrian green would then run until the associated traffic phase terminates. Once the window time expires demands will not be accepted by the controller.

Individual circumstances will dictate the best solution but generally the simplest approach is for parallel pedestrian phases to always appear then run until the associated traffic phase terminates.

When parallel pedestrian phases terminate at the end of a stage, traffic phase delays can be used with the fixed all red that follows the pedestrian green but cannot be used with the variable all red clearance period. When existing traffic signals with farside pedestrian facilities are converted to nearside, fixed traffic phase delays should be carefully reviewed.

Pedestrian on-crossing detection can be very helpful in minimising the clearance after a pedestrian stage, particularly if pedestrian flows are not too high. This can mitigate the impact of some of the issues raised above.

### 6.3 Linking

When developing timing plans for linking of junction traffic signals, particular care needs to be taken to ensure that should the variable Puffin clearance period run to maximum, the integrity of the plan is not compromised.

## 7 PDU ORIENTATION

### 7.1 Introduction

See-through creates a risk of pedestrians viewing an incorrect pedestrian display and crossing when traffic has right of way. This has always been an issue with farside pedestrian heads, particularly at junction traffic signals or staggered mid block crossings, and Puffin facilities suffer from similar problems. See-through should be considered at the design stage and during safety audits as well as when commissioning.

Nearside indicators can be orientated to reduce the risk of see-through. Reduced angle of view PDUs will enable see-through to be avoided without having to point PDUs into the carriageway which could be confusing for some pedestrians.

### 7.2 Central Refuge Area

When central refuge areas are used on straight across crossings, it would be confusing for pedestrians if a red signal were displayed on the central refuge area when they were properly clearing the crossing. To avoid this, PDUs on central refuge areas are provided with a blackout period after the green signal unless the PB is pressed when it immediately changes to red. To minimise the risk of confusing pedestrians, many local authorities try not to use central refuge areas (and the associated blackout) unless essential.



*PDUs on central refuge area incorrectly aligned*

On-crossing detection should cover the full crossing width including the central refuge area. Kerbside detection should generally be provided on the central refuge island and PDUs should be angled:

- on a two way road: two PDUs angled into the carriageway at 25 to 30 degrees so that when standing on the footway looking into the crossing pedestrians will be looking towards the nearest approaching traffic. The chance of the PDU being seen by approaching traffic is then also minimised; and
- on one way roads: a PDU is located on the approaching traffic side with a PB on the leaving side, both of which should be angled at ninety degrees to the direction of travel.



*Reduced angle of view PDU (Copyright Sheffield City Council. Reproduced by permission.)*



*See-through at junction traffic signals*



*See-through at a triangular island*

### 7.3 Staggered Mid Block Crossings

PDU on the central reserve area at staggered mid block crossings must be orientated so that there is no risk of see-through by pedestrians waiting on the outer footways and also in a manner that minimises the risk of drivers seeing the same PDU and being confused by the pedestrian signals. Potential problems of intervisibility should be considered at the design stage. Left/right staggered crossings tend to increase this type of problem whilst right/left staggers tend to reduce them but once the stagger approaches seven metres or more see-through is usually not an issue.

To overcome see through problems the PDUs on the central reserve area should not be set pointing at thirty degrees into the footway but rotated back towards the carriageway and if necessary pointing into the carriageway. The exact angle required can be calculated on drawings knowing the angle of view of the PDU or determined on site. Using reduced angle of view PDUs may avoid the need to point PDUs into the carriageway.

### 7.4 Islands at Junction Traffic Signals

Islands at junction traffic signals, particularly triangular shaped islands, create particular PDU intervisibility problems for pedestrians and drivers. The potential problems of intervisibility must be considered at the design stage in order that a safe and efficient layout can be developed. Possible solutions that can be used to overcome this problem include:

- a) PDU orientation;
- b) use of reduced angle of view PDU;
- c) modifying the staging so the problems are minimised;
- d) using street furniture to mask remote PDUs, e.g. traffic signs, traffic signal poles or lighting columns; or
- e) locating crossings to avoid the problem.

If PDUs are being orientated to avoid see through problems the angle can be determined at the design stage and verified on site. The diagram below shows the required orientation for reduced angle of view PDUs.

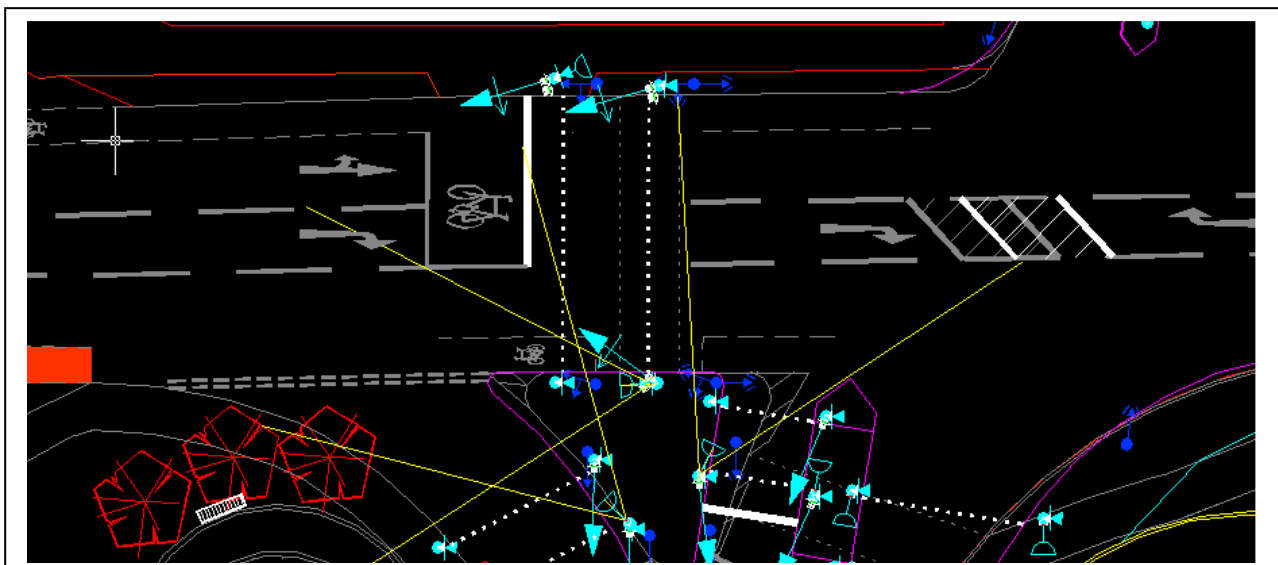

*Designing PDU alignment to avoid see-through (Copyright Bristol City Council. Reproduced by permission.)*

## 8 TIMINGS

### 8.1 Approach

DfT advice for Puffin timings has been updated and issued in TAL 5/05 and is intended to be applicable to mid block crossings as well as junction traffic signals.

The new guidance seeks to establish ‘crisp’ but safe operation. The use of a Pedestrian Comfort (Pc) time allows the maximum possible clearance time to be adjusted as appropriate for local needs. Typically Pc will be three seconds, but could be increased when pedestrian flows are high or slow moving pedestrians are expected or reduced if this was not the case.

The nine standard Puffin timing periods are shown in the table below. The diagrams on the next page illustrate the variable clearance period.

All timings should be calculated as described but verified on site to ensure safe and effective operation for all road users. It should be noted that the use of unnecessarily long fixed timings to protect pedestrians can increase accident risk by creating confusion.

### 8.2 General Timings

#### *Period 1: Traffic Green*

Traffic green minimum is typically seven seconds but may exceptionally be set in the range 6 to 15 seconds if necessary at mid block crossings. The maximum can be set up to 60 seconds according to traffic flows but typically maximum timings over 30 seconds at mid block crossings should be avoided to minimise pedestrian delay.

#### *Period 2: Leaving Amber*

The mandatory three seconds amber signal is used.

#### *Period 3: All Red following Traffic*

For junction traffic signals TA16/81 should be used but for mid block crossings the all red following traffic should be:

- a) one second after a gap change or one, two or three seconds after a force change on low speed roads; but
- b) three seconds when the 85 percentile speed is greater than 35 mph.

This period allows traffic to clear before pedestrians are given right of way but setting it unnecessarily high can create sluggish operation and encourage pedestrians to ignore the signals.

#### *Period 4: Invitation to Cross*

The invitation to cross varies between four and nine seconds. Typically four or five seconds will be used when pedestrian flows are light/moderate. Timings should be increased when:

- a) there are heavy pedestrian flows;
- b) the length of the crossing is greater than 11 metres;
- c) a central refuge area is provided;
- d) space in the pedestrian waiting area is limited;
- e) at crossings on high speed roads; or
- f) if there are high proportions of disabled, elderly or slower moving pedestrians or schools nearby.

**PUFFIN TIMING PERIODS AND TIMING RANGES**

Period	Signals to		Timings (seconds)	Comments
	Pedestrians	Traffic		
1	Red	Green	Minimum 6 to 15 Maximum to 60	Minimum usually 7 can be increased to 15 seconds.
2	Red	Amber	3	Leaving amber
3	Red	Red	1, 2, or 3	All red following traffic
4	Green	Red	4 to 9	Invitation to cross
5	Red	Red	1 to 5	Fixed all red
6	Red	Red	0 to 30	Variable all red
7	Red	Red	0 to 3	Additional all red after Period 6 runs to maximum and pedestrians still detected.
8	Red	Red	0 to 3	Additional all red after Period 6 gap changes.
9	Red	Red & amber	2	Starting amber

PUFFIN TIMINGS VARIABLE CLEARANCE										
<b>Minimum Change</b>										
Vehicle signal	Green		Yellow	Red			Yellow	Green		
Pedestrian signal	Red			Green	Minimum clearance		Red			
Period	1	2	3	4	5	9	1			
<b>Gap Change</b>										
Vehicle signal	Green		Yellow	Red			Yellow	Green		
Pedestrian signal	Red			Green	Clearance between minimum and maximum		Red			
Period	1	2	3	4	5	6	9	1		
<b>Maximum Change</b>										
Vehicle signal	Green		Yellow	Red			Yellow	Green		
Pedestrian signal	Red			Green	Maximum clearance		Red			
Period	1	2	3	4	5	6 (maximum value)	9	1		
<b>Notes:</b>										
<ol style="list-style-type: none"> <li>1. In a 'minimum change' Period 6 (variable all red) does not appear as there are no pedestrians on the crossing at the end of Period 5 (fixed all red);</li> <li>2. In a 'gap change' Period 6 appears but pedestrians clear the crossing before the maximum value is reached and Period 6 gaps off;</li> <li>3. In a 'maximum change' pedestrians are on the crossing until the end of period 6 and Period 6 runs to a maximum;</li> <li>4. Period 7 (fixed all red) would appear in a 'maximum change' but has zero seconds duration; and</li> <li>5. Period 8 (fixed all red) would appear in a 'gap change' but has zero seconds duration.</li> </ol>										

With nearside displays pedestrians cannot see the green signals once they enter the crossing therefore there is no benefit in unnecessarily increasing the duration of Period 4.

#### ***Period 5: Fixed All Red***

Period 5, the fixed all red, is used to ensure that pedestrians who enter the crossing at the end of Period 4 are established on the crossing.

Period 5 can be set in the range of one to five seconds. Three seconds is recommended as the base setting however two seconds has been successfully used at a number of sites. This

timing should always be carefully checked on site because it is linked to the set up of the on-crossing detection which is critical to pedestrian safety.

The fixed all red period will always appear whether or not pedestrians are present on the crossing therefore this timing should not be unnecessarily long.

#### ***Period 6: Variable All Red***

Period 6, the variable all red, is used to hold traffic on red whilst pedestrians clear the crossing. The maximum value of Period 6 is based on road width and the pedestrian 'comfort factor' (Pc).

### Variable Clearance Times

After the green pedestrian signal the clearance time varies between a minimum and a maximum according to pedestrian on-crossing detector extensions:

- the minimum clearance time is equal to the fixed all red timing (P5); and
- the maximum clearance time is equal to the fixed all red timing (P5) plus the variable all red (Period 6).

In practice the actual clearance time at Puffin facilities will vary between these values.

Period 6 will have a zero second duration if there are no pedestrians on the crossing but will run to a maximum if there are pedestrians present or gap out between the minimum and maximum when pedestrians leave the crossing.

#### ***Period 7: Additional All Red after Period 6 runs to Maximum***

This period has been taken account of in Period 6 and should be set to zero seconds.

#### ***Period 8: Additional All Red after Period 6 Gap Changes***

This period has been taken account of in Period 6 and should be set to zero seconds.

#### ***Period 9: Starting Amber***

The mandatory two second amber signal is used.

### 8.3 Other Timings

The following timings should be specified otherwise controller default timings will be utilised which may reduce operational efficiency:

- a) kerbside detector extension time;
- b) registered demand extension time; and
- c) on-crossing detector extension time.

#### ***Kerbside Detector Extension Time***

The kerbside detector extension time is the time a pedestrian demand will be held by the controller after the kerbside detector output terminates. This timing is adjustable in the range of 1 to 5 seconds but typically one second should be used.

### ***Setting Fixed and Variable Clearance Timings***

Period 6 is calculated as follows

$$P6 = [(L/1.2 + Pc) - P5]$$

where:

L is the length of the crossing in metres; and  
Pc is the Pedestrian Comfort time in seconds.

Pc should be selected to reflect local site circumstances (young or elderly pedestrians, proximity to schools etc) and crossing width. Experience to date has shown three seconds to be a reasonable base setting that can be fine tuned on site if necessary. Pc could be varied by time of day to cater for special local needs.

The calculation of the total clearance time (Periods 5 and 6) is based on a walking speed of 1.2 metres/second which is equivalent to the traditional method of calculating fixed period times.

The minimum and maximum clearance times are as follows:

- the minimum clearance time is equal to Period 5; and
- the maximum clearance time is equal to Period 5 plus 6.

### ***Concurrent Timings***

When controllers operate in concurrent mode then

$$P6 = [L/1.2 + Pc]$$

The minimum and maximum clearance times are as follows:

- the minimum clearance time is equal to Period 5; and
- the maximum clearance time is equal to Period 6.

#### ***Registered Demand Extension Time***

The registered demand extension time is the time a pedestrian demand will be held by the controller after the kerbside detector extension time expires. This timing is adjustable in the range of 1 to 5 seconds but typically one second should be used.

**On-Crossing Detector Extension Time**

When on-crossing detectors detect pedestrians on the crossing they will provide an output and the controller will use this output to extend Period 6. This timing is adjustable in the range of 1 to 5

seconds but typically a one second extension time should be used. It should be noted on-crossing detectors may have an in-built manufacturer specific lag before the output is terminated. If the duration of this lag is adjustable typically it should be set as low as possible.

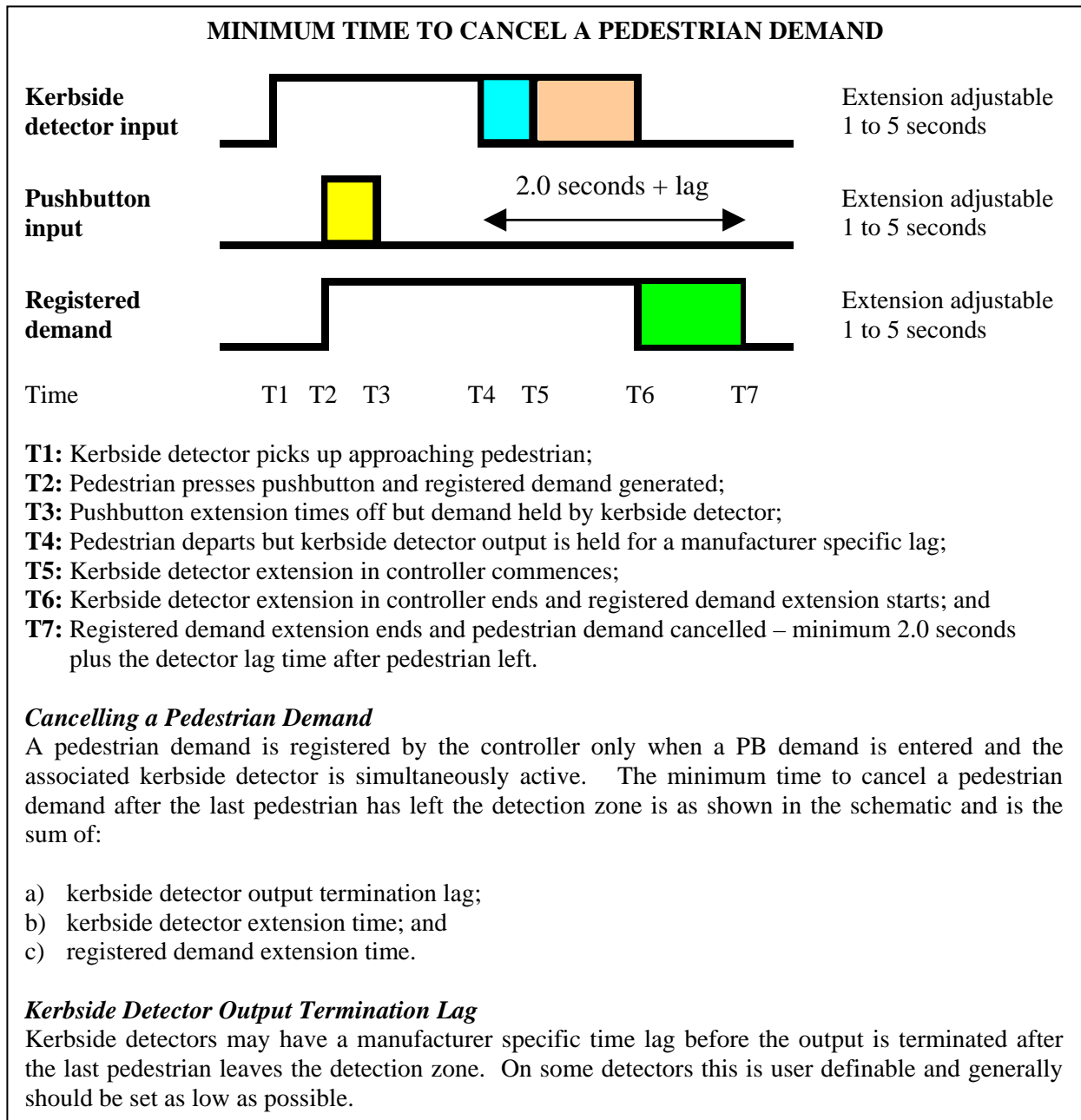

## 9 INSTALLATION, COMMISSIONING, SAFETY AUDITS AND MAINTENANCE

### 9.1 Installation

All pedestrian detection, including PBs, should have its own input within the traffic signal controller and cabling should be specified accordingly. This:

- a) allows optimum monitoring;
- b) provides flexibility within the controller to individually specify the exact function of each detector; and
- c) also gives flexibility to adjust functions of detectors as necessary.

PDUs and PBs run at extra low voltage. This can be achieved by mounting transformers in the controller, within the nearest traffic signal head or in pole mounted boxes or cabinets.

#### Installation Checks

Check that:

- all above ground vehicle and pedestrian detector brackets are fully tightened otherwise the detectors will drop; and
- all wiring is firmly terminated or pedestrian detection will fail to operate correctly.

### 9.2 Commissioning

Commissioning Puffin pedestrian detection is critical for safety and efficiency. Following correct procedures will ensure Puffin facilities are safe and give optimum benefits to both pedestrians and vehicular traffic. Commissioning procedures for kerbside and on-crossing detection are provided in Appendices F and G.

### 9.3 Safety Audits

Safety audits address general safety issues and do not address specific technical issues. This Guide provides the necessary information for safety auditors to understand how Puffin facilities should work but auditors should seek advice from technical specialists when required.

### 9.4 Maintenance

Puffin operational checks should be undertaken at not more than twelve month intervals to ensure that safety and efficiency are maintained as

#### Commissioning Checklist

Traffic heads:

- correctly aligned;
- ensure at least two heads always visible to drivers when approaching and at least one visible to drivers when stationary at the stopline. (This also ensures that in the event of a lamp failure there will still be one remaining fully operational traffic signal head visible to approaching drivers);
- at mid block crossings with nearside primary and secondary heads ensure the latter is visible to approaching drivers. If the primary head obstructs the view of the secondary head, set back the primary head 500mm to ensure the secondary head is visible to approaching drivers; and
- primary hoods used on all heads at mid block crossings and also closely associated secondary heads at junction traffic signals.

PDUs, high level repeaters and PBs:

- correctly located from kerb/studs;
- PDUs between waiting pedestrians and nearest approaching traffic;
- PB and tactile unit always available to the right and correctly angled;
- audible devices and tactile units work correctly;
- pedestrians have clear view of at least one signal;
- green figure 'walking' towards the crossing;
- pedestrian see-through minimised;
- driver's view of PDUs minimised; and
- high level repeater and PDU compatible.

Kerbside detection:

- pedestrian wait area fully covered; and
- above ground detection 'view' of waiting area unobstructed.

On-crossing detection:

- crossing fully covered; and
- on-crossing detectors not obstructed.

defined in TD 24 'All-Purpose Trunk Roads Inspection and Maintenance of Traffic Signals and Associated Equipment'. Requirements for operational checks are given in Appendix H.

All staff undertaking installation and maintenance works should be competent with appropriate accreditation through Sector 8 or other equivalent training and assessment.

## 10 PUBLICITY AND TRAINING

### 10.1 Publicity

There is still misunderstanding in some areas regarding the sequence and meaning of pedestrian signals. This is mainly due to the variety of pedestrian signals currently used but it is hoped that standardising on nearside pedestrian displays will clarify the situation.

A leaflet, 'How to use a Puffin', is available from the DfT and a new leaflet and a poster, which will also be available in multiple languages, is being developed. Leaflets can be obtained from the address given in Appendix B. A short film explaining how to use Puffin crossings has been prepared by the DfT and copies are also available from the address given in Appendix B or can be downloaded from the DfT website. Versions are available to play on a computer or a DVD player and with and without subtitles.

When Puffins are first introduced to an area leaflets should be circulated to schools, colleges, libraries and other community buildings as well as shops and old people's homes before switch on. Some authorities are:

- a) trialling personal demonstrations on site by road safety officers for vulnerable road users; and
- b) displaying a laminated information leaflet for 7 to 14 days attached to a signal pole at each side of the crossing.

When Puffins are well established in an area additional publicity may not be required. When required, publicity should be targeted at adults, particularly the elderly or vulnerable users, as well as children. This can be provided in many different ways including through interest groups, ward councillors, social services or other local authority departments or by distributing leaflets in public buildings, GP's surgeries, old person's homes, bus stations, schools or other education facilities or as inserts in free newspapers. It may also be possible to use local radio or local papers to highlight issues or provide on site advice to pedestrians, particularly when converting farside pedestrian signals to nearside Puffin displays.

### 10.2 Training of School Children

It is essential to ensure that as Puffins are introduced into a town or city appropriate training is provided for school children. As many children

will for some time have to deal with both nearside and farside pedestrian facilities, the focus of the training should be the meaning of the pedestrian display regardless of its location. Current training initiatives include:

- a) an indoor Puffin training facility has been developed by Sheffield City Council and South Yorkshire Police. In the 2004/2005 academic year, over 11,500 Year 6 school children from 305 schools attended the facility; and
- b) a worksheet for use with primary school children has been developed by Darlington Borough Council. This is attached as Appendix I.

The short film prepared by the DfT is a resource which can be used for general publicity and as a training aid.



*The Sheffield indoor training facility  
(Copyright Sheffield City Council. Reproduced by permission.)*

### 10.3 School Crossing Patrols

School crossing patrols should be fully briefed on the implications of Puffin facilities and the DfT Puffin leaflet will provide relevant background. To avoid risk of the crossing patrol being stranded in the crossing after the last child clears the carriageway, consideration could be given to extending the variable clearance time or the on-crossing detection extension time for the phase(s) used by the crossing patrol by time of day. If very high volumes of school children use the crossing, or for a Walking Bus crocodile, the pedestrian green could be increased by time of day or using a key operated facility to extend the pedestrian green signal as long as required or for a fixed period.

## 11 EXISTING PUFFIN FACILITIES

### 11.1 Introduction

Many Puffin crossings have been installed for some time and not all will comply with the requirements of this Guide. Reviews of existing facilities should be undertaken to ensure that they are operating in a safe and efficient manner.

As suitable resources to undertake reviews will inevitably be limited, some prioritisation should be followed, for example:

- a) sites with high accident rates;
- b) general timing reviews because correction should be possible at minimum cost;
- c) pedestrian on-crossing detection review. On-crossing detection is relatively straightforward to adjust and offers significant benefits;
- d) pedestrian kerbside detection reviews. At some mid block crossings implementing pre-timed maximum and removing kerbside detection may be an option; and finally
- e) general hardware checks/upgrades.



*PDU's incorrectly installed on the leaving side*

### 11.2 Timings

Timings will almost certainly not comply with the latest advice but this is something that can be quickly checked and corrected at minimal cost.

The general timing periods should be checked as well as the other pedestrian related timings. The operation of the detection should also be checked using the procedure given in Appendix H.

### 11.3 Operational Check

Three aspects of pedestrian detection need to be checked:

- a) kerbside detection;
- b) on-crossing detection; and
- c) establishing pedestrians onto the crossing.



*On-crossing detector hidden behind the backing board*

These checks should be undertaken at not more than twelve month intervals and could be included as part of the annual maintenance inspections. Appendix H provides procedures for operational checks that could also be undertaken by non-specialised staff at other times if required.

### 11.4 Other problems

Other problems with older Puffin installations may include:

- a) poor pole positioning;
- b) poor tactile paving layout;
- c) poor orientation of nearside pedestrian displays;
- d) poles/pushbutton positioned more than 500mm from edge of tactile paving; and
- e) poor installation of pedestrian kerbside and on-crossing detection.

Once the problems are identified measures to correct the deficiencies should be put in place.



*PDU's on refuge incorrectly aligned*

## 12 CASE STUDIES

### 12.1 Introduction

This section presents a number of case studies that show how local authorities are actually implementing Puffin facilities and operational benefits being achieved.

### 12.2 Puffin Operational Review

Scarborough Borough Council (acting as agent for the Highway Authority, North Yorkshire County Council) has recently commenced a review of all mid block Puffin crossings in Scarborough. The objectives were to:

- a) ensure all pedestrian detection was correctly set up and operating;
- b) determine when pre-timed maximum would be more appropriate and remove kerbside detection at these locations; and
- c) adjust timings to be in line with the latest DfT advice.

A pilot covering two sites has been completed:

- a) the first site was on a major radial and kerbside pedestrian detection was retained to reduce traffic delay and cancel unnecessary demands entered by passing school children. The timings were adjusted and one faulty kerbside detector replaced. Overall operation was improved; and
- b) the second site was on a less important traffic route but was heavily used by pedestrians. Kerbside pedestrian detection was switched off and pre-timed maximum was implemented reducing pedestrian delay without significantly impacting on traffic delay.

All other mid block Puffin crossings in Scarborough are now being reviewed.

### 12.3 Conversion of Farside Pedestrian to Puffin Facilities at Junction Traffic Signals

The City of York Council has completed conversion of two isolated junction traffic signals with an all red pedestrian stage from farside pedestrian facilities to nearside Puffin style facilities. The impact of this change was assessed as part of the DfT's UG336 project and the preliminary results are shown below.

Both sites are located on one of the major radial routes into York with high peak hour traffic flows into the City during the AM peak and outbound in the evening. Pedestrian flows are significant (around two hundred pedestrians per hour) but not so high that pedestrian demands are never cancelled. The results are based on five weekdays 'before' and five weekdays 'after' data collected between 07.00 and 19.00 hours on each day.

### 12.4 Pole Installation

To ensure the PDU or PB is accessible to pedestrians, current DfT advice is to install poles:

- a) not more than 500mm from the line of crossing studs; and
- b) with 500mm clearance from the kerb face. Note this may need to be increased in some circumstances, for example when the crossfall is excessive.

As the diagram below shows, when the pole is installed 500mm from the face of the kerb, this results in a clearance of only 250mm from the signal head to the line of the kerb, less than the 450mm recommended in TD 50 and LTN 1/98.

RESULTS OF TRIALS IN YORK		
Topic	Site 1	Site 2
Change in cycle time	Average fell from 96 to 75 seconds	Average fell from 88 to 79 seconds
Pedestrian demands cancelled	32%	28%
Reduction in 'lost time' resulting from the all-red pedestrian stage	8 seconds (on average)	5 seconds (on average)
Reduction in pedestrian delay	10 seconds	3 seconds
Reduction in vehicle delay	<ul style="list-style-type: none"> <li>• Peaks - 10 seconds in direction of main flow</li> <li>• Off peak - slight drop in both directions</li> </ul>	<ul style="list-style-type: none"> <li>• Peaks - 10 seconds in direction of main flow</li> <li>• Off peak - slight drop in both directions</li> </ul>

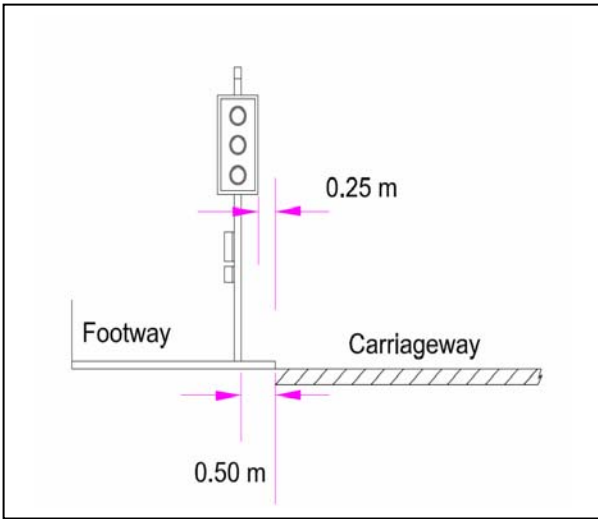

*Straight pole clearance when set back 500mm from the face of the kerb*

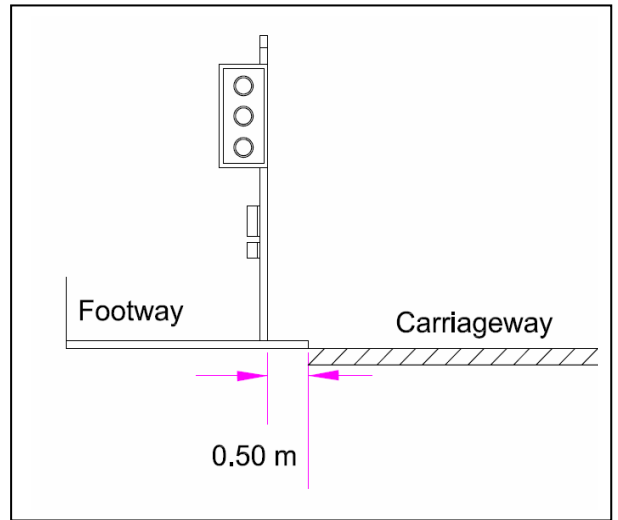

*Using brackets to maintain clearances*

To maintain the required 450mm clearance for signal heads, the pole would have to be set back a further 200mm from the kerb face. Alternatives that maintain both the clearance of the pole from the kerb and the head clearance are:

- a) use cranked poles; or
- b) use brackets to offset the head.

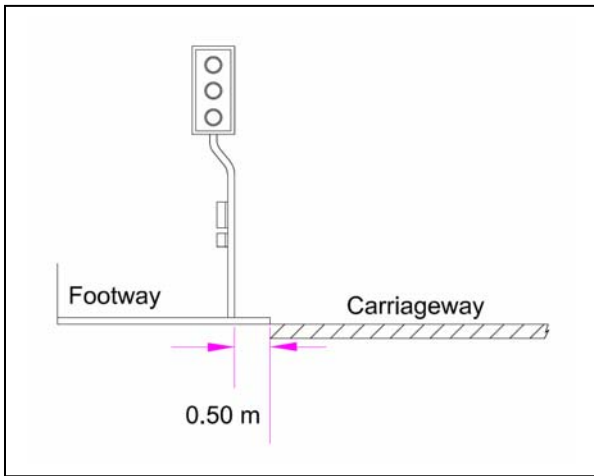

*Using cranked poles to maintain clearances*

## GLOSSARY

**BSI** – British Standards Institution  
**BS** - British Standards Institute specification  
**DfT** - Department for Transport\*  
**ELV** – Extra Low Voltage  
**FT** – Fixed Time  
**HA** - Highways Agency  
**ILE** – Institute of Lighting Engineers  
**Kerbside detector** – Detection used to detect the presence of a pedestrian  
**LINSIG** – Junction modelling software produced by JCT consultancy  
**MOVA** - Microprocessor Optimised Vehicle Actuation  
**LTN** – Local Transport Note, Department for Transport publication  
**On-crossing detector** – Detector used to detect the presence of a pedestrian on the carriageway crossing  
**PB** – Push Button, pedestrian demand pushbutton only  
**PDU** – Pedestrian Demand Unit, incorporating both a pedestrian pushbutton and nearside indicator  
**PELICAN** – Pedestrian Light Controlled crossing  
**PUFFIN** – Pedestrian User Friendly Intelligent Crossing  
**SCOOT** – Split Cycle Offset Optimisation Technique  
**Statutory Instrument** – Act of Parliament  
**Tactile Paving** – Paving slabs (or bricks) that have a raised ‘blister’ surface of a series of 25mm. domes that assist visually impaired pedestrians to locate a pushbutton / nearside indicator  
**TAL**– Traffic Advisory Leaflet - Department for Transport publication  
**TA/TD** – Trunk Road Standard and Advice Note  
**TR** – Highways Agency Specifications  
**TRL** – Transport Research Laboratory  
**UTC** – Urban Traffic Control  
**VA** - Vehicle Actuated

\*The Department for Transport (DfT) has been known formerly as:

**DTLR** (Department for Transport, Local Government and the Regions); and  
**DETR** (Department of the Environment, Transport and the Regions).

**APPENDIX A**  
**DESCRIPTION OF PUFFIN OPERATION**

# PUFFIN PEDESTRIAN FACILITIES

## Introduction

Puffin pedestrian facilities have been developed to provide improved operation for pedestrians and to reduce delay for both drivers and pedestrians. This is achieved by:

- using positive and unambiguous nearside pedestrian displays;
- providing consistent displays to drivers;
- cancelling pedestrian demands when pedestrians cross in gaps; and
- varying the clearance time after the pedestrian green signal to allow slow pedestrians to cross without harassment from drivers.

Puffin facilities can be implemented at both traffic signal junctions and mid block crossings (pedestrian, Toucan and equestrian) and irrespective of the control strategy used.

It is the Department for Transport's intention that Puffin pedestrian facilities will become the standard form of provision of signalled pedestrian crossings. This will provide a consistent approach at junction traffic signal and mid block crossings (including Toucans and equestrian crossings) as well as operational benefits for all road users.

## Pedestrian Displays

Prior to the introduction of Puffin facilities, pedestrian heads at mid block crossings and

junction traffic signals were located on the farside of the crossing. With Puffin facilities



*Puffin nearside pedestrian display in foreground with approaching traffic in the background*

nearside pedestrian displays are used and pedestrians are presented with a steady red or green signal.

Potential pedestrian confusion is reduced because:

- the flashing green pedestrian signal used at Pelican crossings is no longer required; and
- blackouts are not used (the only exception to this is when there are central refuge areas at straight across crossings).

With farside pedestrian signals, pedestrians look away from approaching traffic to see the pedestrian signal. When pedestrians look at a nearside Puffin pedestrian display they are also looking in the direction of approaching traffic.

Seeing the approaching traffic and the pedestrian display at the same time should reduce accident risk.

Pedestrians with sight problems (and it is estimated up to two million pedestrians fall into this category) also should find it easier to see a nearside pedestrian display compared to a pedestrian signal at the opposite side of the carriageway.

## Driver Displays

The flashing amber signal used at Pelican crossings can encourage aggressive driver behaviour. With Puffin facilities this problem is minimised because a steady red signal, similar to traffic displays at junction traffic signals, is displayed to drivers when pedestrians are crossing. Consistency of driver displays at mid block crossings and junction traffic signals will also reduce the risk of driver confusion.



*Puffin nearside pedestrian display*

## cancelling Pedestrian Demands

At non-Puffin facilities when a pedestrian demand is entered the pedestrian phase must run even if the pedestrian has crossed in gaps in traffic. At Puffins, kerbside detection is used to monitor if pedestrians are present and cancel demands when pedestrians cross in gaps. This will help to alleviate driver frustration caused by unnecessary delays.



*Mid block Puffin*

## Variable Clearance Times

At mid block crossings and junction traffic signals with farside pedestrian heads, the clearance time after the pedestrian green is fixed. On-crossing detection at Puffin facilities is used to vary the pedestrian clearance times between defined minimum and maximum times:

- when there are large numbers of pedestrians or if slow moving pedestrians are crossing, the clearance time is extended to provide

pedestrians with the time they need to cross in safety; but

- when there are no pedestrians on the crossing, the clearance time is minimised.

Typically the average clearance time will be reduced compared to the fixed clearance period reducing traffic delay.

## Benefits of Puffins

Compared to farside pedestrian facilities at junction traffic signals, Puffin facilities:

- will simplify displays to pedestrians;
- will assist slow moving pedestrians to cross in safety;
- typically will reduce traffic delays; and
- typically will reduce pedestrian delays.

Converting junction traffic signals can benefit both traffic and pedestrians. Conversion of Pelican to Puffin crossings will simplify displays to pedestrians and drivers, assist slow moving pedestrians to cross in safety and have little impact on or reduce traffic delays.

## Publicity and Training

When Puffins are introduced, especially the first few facilities in an area of a town or city, publicity should be issued. A leaflet, 'How to use a Puffin' is available from the DfT. The DfT also intends to update this leaflet in different languages and produce posters.

Training of school children is important and should be provided when Puffin facilities are introduced. Provision of information to other groups, particularly the elderly, should also be provided when appropriate.

It is inevitable that there will be a mixture of pedestrian control strategies on-street during the transition process to full Puffin implementation and publicity should take this into account.



*Puffin facilities at junction traffic signals*

## Funding for Conversion to Puffins

The efficiency benefits offered by Puffin facilities, particularly at junction traffic signals, can assist Local Authorities meet the objective of the Traffic Management Act 2004.

Mobility for many pedestrian groups, including the disabled, older pedestrians and mothers with young children, can be improved by Puffin facilities. Funding for conversion of existing facilities to Puffins could therefore be sought through the LTP process.

**APPENDIX B**

**RELEVANT DOCUMENTATION**

## LTNs

- LTN 1/98 – The Installation of Traffic Signals and Associated Equipment
- LTN 2/95 – The Design of Pedestrian Crossings

## TAs

- TA 16/81 – General Principles of Control by Traffic Signals
- TA 57/87 – Roadside Features
- TA 84/01 – The Code of Practice for Traffic Control and Information Systems (MCH 1869)

## TALs

- TAL 4/91 – Audible and Tactile Signals at Pelican Crossings
- TAL 5/91 – Audible and Tactile Signals at Signal Controlled Junctions
- TAL 4/98 – Toucan Crossing Development
- TAL 1/01 – Puffin Pedestrian Crossings (DETR)
- TAL 1/02 – The Installation of Puffin Pedestrian Crossings
- TAL 2/03 – Signal Controlled Junctions on High Speed Roads
- TAL 3/03 – Equestrian Crossings
- TAL 5/03 – Walking Bibliography
- TAL 5/05 – Pedestrian Facilities at Signal Controlled Junctions

## TDs

- TD 24 - All-Purpose Trunk Roads Inspection and Maintenance of Traffic Signals and Associated Equipment
- TD 50 – The Geometric Layout of Signal Controlled Junctions and Signalised Roundabouts.

## TRs

- TR0155B – Audible Unit for use at Pelican Crossings
- TR0157B – Tactile Equipment
- TR2182B – Specification for Kerbside Pedestrian Detection Systems
- TR2206A – Specification for Road Traffic Signals
- TR2500 – Specification for Traffic Signal Controller
- TR2506A (superseding TR2179B) - Specification for Above Ground On-crossing Pedestrian Detection Systems

## Street Lighting

- BS5489-1:2003 - Code of Practice for the Design of Road Lighting (BSI)
- CEN/TR 13201-1:2004 - Road Lighting (BSI)
- TR 12 1997 - Lighting of Pedestrian Crossings (ILE)

## Other

- How to use a Puffin Crossing (DfT leaflet)
- BS7518: 1995 – Pedestrian Restraint Systems in Metal
- Chapter 1 and 5 of the Traffic Signs Manual
- Design Manual For Roads and Bridges.
- DfT Manual for Streets
- DfT Walking and Cycling Plan
- Guidance on the use of Tactile Paving Surfaces
- IHT Guidelines - Providing for Journeys on Foot
- Inclusive Mobility
- The Zebra, Pelican and Puffin Pedestrian Crossings Regulations and General Directions 1997
- Traffic Signs Regulations and General Directions (2002)
- Transport in the Urban Environment
- TRL Report 364 – The Puffin Pedestrian Crossing: Experiences with the First Experimental Sites

## Obtaining Publications

Publications can be obtained as follows:

- Stationery Office (0870 600 5522) for LTNs, TAs, TDs, acts and regulations
- Highways Agency Plans Registry website ([www.tsplansregistry.org](http://www.tsplansregistry.org)) for TRs
- Department for Transport (020 7944 2974) for TALs. For 'Guidance on the use of Tactile Paving Surfaces' and 'Inclusive Mobility' 0870 1226 236

## Obtaining the 'How to Use a Puffin' leaflet and Puffin film

PO Box 236  
Wetherby  
West Yorkshire LS23 7NB  
Tel: 0870 1226 236  
Fax: 0870 1226 237  
Email: [dft@twoten.press.net](mailto:dft@twoten.press.net)

**APPENDIX C**  
**FREQUENTLY ASKED QUESTIONS**

Question	Answer
How much more does a mid block Puffin cost to implement than a Pelican?	The estimated additional cost of installing a new Puffin crossing compared with a new Pelican crossing is approximately £2500. This is due to additional items of equipment required for Puffin operation. The cost of converting an existing Pelican crossing to a Puffin crossing may be higher depending on local factors including general site and equipment improvements made at the same time.
Why does the DfT not carry out a national publicity campaign?	Although the Puffin crossing concept has been around for some years there are not yet sufficient numbers to justify a national publicity campaign. It may be seen as a wasted exercise if a large proportion of the target audience have not come across a Puffin crossing.
What is the main difference between a Puffin crossing and other types of signal controlled crossings?	The fundamental feature of Puffin crossing is the nearside pedestrian signal compared with other types of crossings that have a pedestrian signal on the farside of the crossing. The pedestrian signal at Puffins is normally mounted on the primary pole to allow waiting pedestrians to have a clear view of approaching traffic, which is their nearest point of conflict, and the pedestrian signal simultaneously.
Why was there a need to develop a Puffin Crossing?	Puffin development was initially supported by the European Community Drive programme. Two full scale trials took place in the UK. The results are reported in Research Report 364, 'The Puffin Pedestrian Crossings: Experience with the first Experimental Sites' (available from TRL). The Puffin (Pedestrian User Friendly Intelligent) concept was developed by the DfT mainly in response to complaints from the general public about not having sufficient time to cross the carriageway at junction traffic signals and mid block crossings. At junction traffic signals there were also complaints about the confusion caused when the green man signal goes out whilst they were still on the crossing and the meaning of the blackout. At Pelican crossings complaints were received about intimidation by impatient drivers nudging forward during the flashing green man/flashing amber signal. Members of the public also were unsure what to do if they arrived at a Pelican crossing during the flashing green man/ amber signal period.
What are the main benefits of a Puffin crossing for pedestrians and drivers?	Puffins will provide a standard signal sequence at all types of controlled pedestrian crossings. Benefits for pedestrians are: <ul style="list-style-type: none"> <li>• positive signalling, i.e. signals will remain on red to drivers as long as pedestrians on the crossing;</li> <li>• the variable clearance period provides longer crossing periods when required, which should be of particular benefit to the elderly, disabled people and indeed children who may need more time to cross, but shorter if not required; and</li> <li>• the position of the near side signal should also help visually impaired people using crossings who may not be able to easily discern signals mounted across the road.</li> </ul> For drivers benefits are reduced delays resulting from cancelling unnecessary pedestrian demands and the variable clearance period as well as consistent displays at all controlled pedestrian crossings.

<p>How safe is a Puffin crossing compared with other formal crossing types?</p>	<p>The London Accident Analysis Unit carried out a study in 1996 at five Puffin sites in London and the accident statistics revealed that Puffin crossings were no worse than Pelicans and in some cases they were better. The London Road Safety Unit has also investigated changes in accident rates at 23 Puffin sites in London and identified 15 percent reductions in all accidents and 26 percent in pedestrian accidents relative to control sites. The reality is that accidents and fatal accidents do happen at all crossing types from time to time. Further research is anticipated into accidents at Puffin crossings.</p>
<p>Can pedestrian detection be used at other types of crossings?</p>	<p>With the exception of on-crossing detection at far side Toucan/Equestrian crossings, kerbside and on-crossing detectors are approved for use with Puffin (i.e. nearside signal facilities) only.</p>
<p>Are there any other forms of approved nearside crossings?</p>	<p>Nearside signal controlled crossings comprise: Toucan, Equestrian, pedestrian facilities at junctions, etc. These are prescribed in the current TSRGD 2002.</p>
<p>What guidance is there on Puffin crossings?</p>	<p>For general information on the assessment and design of pedestrian crossings, reference should be made to LTN 1/95 and 2/95. For specific information on Puffin crossings, the following documents may be useful: TAL 5/05, TAL 1/02 and TAL 1/01. The Puffin Good Practice Guide complements existing guidance and provides additional background and supporting detail.</p>
<p>Is it mandatory to use pedestrian on-crossing and/or kerbside detection at Puffin crossings?</p>	<p>There are a number of situations where pedestrian detection (kerbside and/or on-crossing) may not be necessary and some of these include: busy urban sites, walk with traffic on narrow carriageway, mid block crossings with pre-timed maximum, etc. It should however be noted that pedestrian detection plays an important role in traffic management and should not be omitted without a reason.</p>
<p>What evidence is there to show that Puffin facilities cause less vehicle delay than Pelican crossings?</p>	<p>The TRL carried out research for the Department in 1992 following the introduction of new Puffin crossing. The report estimated an average net benefit of approximately £10,000 per site per annum through reduced vehicle delays, giving an overall benefit across the country of about £50 million if installations were to take place at all sites. Work in 2005 at junction traffic signals converted from farside to Puffin facilities showed an average annual rate of return of 325 percent.</p>
<p>What assessment has the Department made of which type of crossing pedestrians prefer?</p>	<p>TRL Report 364 suggested that pedestrians preferred the new style of crossing because of a greater feeling of safety.</p>
<p>What guidance is there to encourage local authorities as to which system to install for newly implemented pedestrian crossings?</p>	<p>The Department issued guidance to practitioners in the form of a Local Transport Note 2/95, 'Design of Pedestrian Crossings' which states that the Puffin operational cycle will become the standard form.</p>
<p>Why can pedestrian signals not be installed on the nearside and farside at the same site?</p>	<p>Putting signals on the farside of the crossing re-introduces the confusion caused at existing crossings and whatever information is presented to pedestrians after the green man it will almost always conflict with what pedestrians should actually be doing. For example, if a red man is shown after the green man period then it implies that pedestrian should not continue to cross and if no signal is given then this can also lead to confusion.</p>

<p>Can the zig-zag lines on either side of the controlled zone at a mid block Puffin be of unequal length?</p>	<p>No. Overtaking and stopping of motor vehicles is prohibited within the controlled zone (except for specified exclusions) and the zig-zag markings identify the extent of this restriction. The extent of the zig-zag lines on either side of a driver must therefore be the same to avoid ambiguity and enable enforcement to occur. In some circumstances the provision of a double row of zig-zag markings in the centre of the road will enable the length of the controlled zone on the approach and leaving sides of the carriageway to differ. Reference should be made to the Traffic Signs Manual, Chapter 5, Section 15 for detailed advice.</p>
<p>Can bus or cycle lanes be continued through the controlled zone?</p>	<p>Cycle lane markings should terminate at the start of the zig-zag marking on the approach side of the crossing (no special terminal marking is specified) and recommence at the end of the zig-zag marking on the leaving side of the crossing. A cycle symbol will be required at the recommencement of the cycle lane. See the Traffic Signs Manual Chapter 5 Section 16 for detailed advice.</p> <p>Bus lane markings can be continued through the controlled area of a crossing but not through the crossing point itself. Zig-zag markings will be required on both sides of the bus lane instead of the usual boundary marking to diagram 1049 and must follow the same rules as for other zig-zag markings. For detailed advice see the Traffic Signs Manual Chapter 5 Section 17.</p>
<p>When can zig-zags and advanced stoplines (ASLs) be used?</p>	<p>Where the Puffin facility complies with Direction 54 of TSRGD and its Schedule you can use zig-zags to create a controlled zone but ASLs are not permitted. If the facility does not comply with Direction 54 and its Schedule you can use ASLs but not zig-zags.</p>

**APPENDIX D**  
**PUFFIN RESEARCH**

## **D.1 Introduction**

Since the introduction of Puffin facilities a limited amount of research has been undertaken into the operation and benefits of Puffin facilities:

- a) TRL Report 364;
- b) Highways Agency Puffin Crossing Study;
- c) London Road Safety Unit study into accidents at Puffin Crossings;
- d) Puffin Crossing Operation and Behavioural Study;
- e) Greater Manchester Transportation Unit (GMTU) before and after analysis of accidents at Puffin style facilities;
- f) DfT project UG336 (Puffin operational and behavioural Study);
- g) DfT project UG476 (integration of Puffins into SCOOT); and
- h) DfT project UG272 (pedestrian detection techniques).

Some of the earlier research into Puffin operation and accidents at Puffins was undertaken without the benefit of correct Puffin operation and this may have detrimentally impacted on the research results.

## **D.2 TRL Report 364**

This study was carried out by the TRL and reported in 1992. Two junction traffic signals were converted to Puffin operation and 'before' and 'after' study of technical, operational and behavioural aspects were undertaken. The main conclusions were:

- a) more time was given to individual pedestrians who needed it and to pedestrians when pedestrian flow was higher. Cancelling of unwanted pedestrian demands offset the impact on traffic delay;
- b) pedestrian and vehicle delays were reduced; and
- c) average benefit was estimated at £10,000 per site per year (1992 costs) based on average reductions in pedestrian and vehicle delays.

## **D.3 Highways Agency Puffin Crossing Study**

This study was carried out by the London Accident Analysis Unit and reported in November 1997. A detailed analysis of accident data was undertaken at the first five Pelican sites converted to Puffin crossings in London. Accidents within 50 metres of each crossing were considered over

three years before and three years after conversion. The main conclusions were:

- a) the total number of accidents fell from 34 in the 'before' period to 28 in the 'after'. At four of the five sites accident rates fell but rose on the fifth;
- b) accidents involving pedestrians fell from 12 in the 'before' period to 2 in the 'after';
- c) accidents occurring in the darkness fell from 11 in the 'before' period to 3 in the 'after'; and
- d) accidents on the approaches to the crossings remained the same in the 'before' and 'after' periods.

The authors specifically noted that operational problems with the Puffin facilities had impacted on the data but could not quantify the impact.

## **D.4 The Effects on Accidents on Newly Installed Puffin Crossings**

London Road Safety Unit has conducted an analysis of total and pedestrian accidents at 16 groups (23 sites) of mid block crossings across London. Findings show that for all sites, there were reductions of 15 percent in total accidents and 26 percent in pedestrian accidents relative to control sites.

When grouped by the type of the previous crossing facility, there were reductions in total and pedestrian accidents for nearly all site types compared to control sites:

- a) the number of total accidents fell at Pelican to Puffin conversions by 39 percent and the number of pedestrian accidents by 30 percent;
- b) at zebra crossings converted to Puffins the number of total accidents fell by 14 percent and the number of pedestrian accidents by 8 percent; and
- c) when previously there had been no formal crossing, total accidents rose by 8 percent but the number of pedestrian accidents fell by 35 percent.

## **D.5 Puffin Crossing Operation and Behavioural Study**

This study was undertaken by the TRL for the LRSU and reported in August 2005. The report compared five Puffin sites with five paired Pelican sites across London.

The report concluded:

- a) pedestrians were significantly less likely to begin crossing when shown a steady red signal (at Puffins) compared to a flashing green signal (at Pelicans);
- b) where pedestrian waiting times increased (under UTC) more pedestrians crossed without a green signal;
- c) large numbers of pedestrians crossed without pressing the push buttons, up to 49 percent at one site; and
- d) differences between the observed use of Puffin and Pelican crossings could often be explained by local factors such as location and signal strategy.

The report noted that Puffin timings had been set cautiously and in some cases delayed traffic by seven seconds longer than was necessary. In addition, detection problems at four of the five sites altered the crossing operation and may have affected driver and pedestrian behaviour.

#### **D.6 Before and After Analysis of Accidents at Puffin Style Facilities**

This report summarises GMTU's analysis of road accidents at Puffin Crossings. The analysis covered:

- a) sites converted from Pelican style pedestrian crossings to Puffins; and
- b) sites at which a Puffin has been installed where there was previously no crossing facility.

The report concluded the low numbers of accidents at most sites, both before and after Puffin installation, made it difficult to attach any statistical significance to the results.

There was little change in overall numbers of accidents following the conversion of Pelicans to Puffins but there did appear, however, to have been some increase in pedestrian accidents.

Where completely new crossings were installed, the report concluded numbers of accidents generally fell.

#### **D.7 UG336: Puffin Operational and Behavioural Study**

This study, which is scheduled to be completed in December 2005, is being undertaken by the Ian Routledge Consultancy and the Southampton

University Transport Research Group for the DfT. The study:

- a) is investigating the impact on vehicle and pedestrian delays and pedestrian behaviour at sites converted from Pelican crossings to Puffin crossings;
- b) is investigating the impact on vehicle and pedestrian delays at junction traffic signal converted from traditional farside to nearside Puffin pedestrian facilities;
- c) has undertaken a pedestrian behavioural study of the introduction of high level repeaters; and
- d) is assessing operation of pedestrian detection.

Pedestrian attitude surveys have also been undertaken as part of the assessment of prototype high level repeaters.

#### **D.8 UG476: Integration of Puffins into SCOOT**













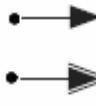
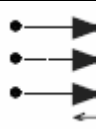
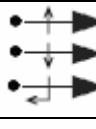
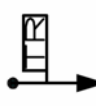

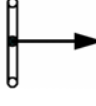
This study is investigating the integration of Puffins into SCOOT in order to improve operational benefits resulting from the variable clearance period.

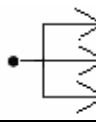









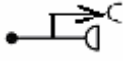



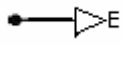

#### **D.9 UG272: Advanced Detection Systems**

This study is investigating the performance of new pedestrian detectors which are starting to become available including infrared, CCTV and laser technologies. With more advanced detectors it should be possible to realise more sophisticated traffic control in order to give a fairer allocation of time to pedestrians at mid block crossings and junction traffic signals to aid specific groups such as elderly or disabled.

**APPENDIX E**

**TRAFFIC SIGNAL SYMBOLS INCLUDING PUFFIN SYMBOLS**

	SYMBOL	APPEARANCE OR DIAGRAM NO. FROM TSRGD <sup>6</sup> AND DESCRIPTION
SIGNALS FOR VEHICLES		Single aspect signal
		Two aspect signal
		3000 with primary visor 3000 with secondary visor*
	Three aspect signal	
		3000.8, 3000.10 Three aspect primary signals with substitute green arrow signals
		3000.7, 3000.9 Three aspect secondary signals with additional green arrow signals
		Three aspect primary signal with box sign. TL-Turn left, TR-Turn right, AO-Ahead only, NLT-No left turn, NRT-No right turn, NUT-No "U" turn Note: TL and NLT normally fitted on left of signals; TR and NRT on right
		Bracket mounted three aspect primary signal
		Three aspect primary signal mounted on mast arm support
		Three aspect primary signal mounted on gantry
		Two three aspect signal heads, one at standard height, one at high level
		3000.2 Three aspect primary signal with cycle symbols for amber and green
		3014 Wig-wag signal
		3013 – 3013.5 Tramcar signal
SIGNALS FOR PEDESTRIANS, CYCLISTS AND EQUESTRIANS		4003, 4003.3, 4003.6, and part of 4003.1, 4003.4, 4003.7 Push button
		4002.1 Two aspect farside pedestrian signal
		Two aspect nearside pedestrian signals 4003.1 without pushbutton
		with restricted field of view
		4003.1 with combined push button (pushbutton)
	4003.1 with separate pushbutton	

<b>SIGNALS FOR PEDESTRIANS, CYCLISTS AND EQUESTRIANS</b>		4003.5 Farside Toucan signal (cycle symbol can be to right or left)
		Nearside Toucan signal (cycle symbol can be to right or left, see TSRGD <sup>6</sup> )
		4003.7 without pushbutton
		4003.7 with combined pushbutton
		4003.7 with separate pushbutton
		4003.2 Two aspect farside Equestrian signal
<b>DETECTORS</b>		Inductive loop vehicle detector
		Inductive loop MOVA vehicle detector
		Above ground vehicle detector
		Above ground stop line vehicle detector
<b>OTHER</b>		On-crossing detector
		Kerbside detector
		Tactile area used as surface kerbside detector
		Photo-electric cell
		Tactile paving
		Guardrailing
	Controller or other equipment housing	

\* Secondary visors have a much reduced field of vision compared to the primary. This is to shield the signal from opposing vehicular traffic, or pedestrians in some cases. However, primary visors can be used in the secondary position, for example at a stand-alone pedestrian crossing, where ahead visibility is paramount. It is important to ensure that this is clear to the supplier/installer. Drawing MCX 0402, Traffic Signal Visors, is available through the Highways Agency, giving details of the two types. All the signals in 1-10 above can have primary or secondary visors, as appropriate.

**APPENDIX F**

**KERBSIDE DETECTOR COMMISSIONING PROCEDURES**

The following procedure should be followed, preferably at quieter times, to commission kerbside detection for each pedestrian waiting area. The signal installation contractor will have previously set up the detection and normally attends the commissioning. A stopwatch will be necessary to check timings.

All controller timings should be checked prior to commissioning to ensure that they are as specified. Any controller fault log entries which could affect the operation of the timings should be cleared, for example detector faults or red lamp faults.

Two people will normally be required to undertake commissioning. For above ground detection, the LEDs on the detectors can generally be used but monitoring of the controller input

ports is preferable and may be necessary for fine tuning or multiple above ground detectors or if in-ground detection is used.

When undertaking commissioning ensure pedestrians in other waiting areas do not influence the commissioning process.

If, as a result of this procedure, any adjustment is made to the kerbside detector or timings, then the procedure should be repeated.

It is also recommended that the operation of kerbside detection is checked in poor and bright light conditions and operational checks defined in Appendix H are carried out within one week of commissioning to verify operation.

### **Procedure for Commissioning Kerbside Detection**

#### *Set up*

- a) Verify correct timings are set in the controller.
- b) Define the pedestrian waiting areas (by observation) and if necessary mark out.
- c) Verify that the kerbside detector is generally operating correctly.
- d) Verify inputs are correctly connected to the controller.

#### *Holding Pedestrian Demands*

- e) Insert a pedestrian demand and confirm the demand is held when a pedestrian is present within the pedestrian waiting area – repeat as necessary to verify coverage of the total waiting area.
- f) Confirm that the kerbside detection can hold a demand entered in another waiting area for the same phase.

#### *Cancelling Pedestrian Demands*

- g) Insert a demand and immediately leave the waiting area. Verify the demand is cancelled after the correct time.
- h) If used, test the additional safety feature described in Section 4.6 by pressing the PB without activating the associated kerbside detector and verify the demand is not cancelled even when there are no pedestrians in the pedestrian waiting area.

#### *Other Pedestrian Waiting Areas*

- i) Repeat for other pedestrian waiting areas.

**APPENDIX G**

**ON-CROSSING DETECTOR COMMISSIONING PROCEDURES**

The following procedure should be followed, preferably at quieter times, to commission the on-crossing detection for each pedestrian crossing point. The signal installation contractor will have set up the site prior to the commissioning tests and will normally attend the commissioning. A stopwatch will be necessary to check timings.

All controller timings should be checked prior to commissioning to ensure that they are as specified. Any controller fault log entries which could affect the operation of the timings should be cleared, for example detector faults or red lamp faults.

Two people will normally be required to undertake commissioning. The LEDs on the

detectors can generally be used but monitoring of the controller input ports is preferable and may be necessary for fine tuning of multiple detectors. Standard walking speeds should be used unless indicated otherwise. It should be noted that current on-crossing detectors are usually set up to monitor the opposite side of the crossing to the pole on which they are installed. The central area of the crossing will therefore be covered by at least two on-crossing detectors.

If, as a result of this procedure, any adjustment is made to the on-crossing detector or timings, then the procedure should be repeated. It is also recommended that the operational checks defined in Appendix H are carried out within one week of commissioning to verify operation.

### **Procedure for Commissioning On-crossing Detection**

#### *Set up*

- a) Verify correct timings are in the controller.
- b) Verify inputs are correctly connected to the controller.
- c) Verify that the on-crossing extensions cease when pedestrians leave the crossing.
- d) Verify that pedestrians walking on the footway past the crossing do not cause the on-crossing detection to extend (note sometimes to ensure pedestrians are established on the crossing the detection zone may extend slightly into the footway).

#### *Fixed All Red (Period 5)*

- e) Insert a pedestrian demand and when the pedestrian green terminates verify (ensuring that the crossing area is clear of pedestrians) the fixed all red runs to the defined time and the controller then reverts to traffic green. This also confirms that the variable clearance runs to zero seconds when there are no pedestrians on the crossing.

#### *Variable All Red (Period 6)*

- f) Insert a pedestrian demand and confirm the variable all red runs to the defined maximum when pedestrians remain on the crossing.
- g) Repeat as necessary to verify coverage is provided over the full crossing area between the studs.
- h) Insert a pedestrian demand and confirm the variable all red runs when pedestrians are on the crossing but gaps out when pedestrians exit the crossing.
- i) Repeat as necessary to verify coverage is provided over the full crossing area.
- j) As part of the above verify Periods 5 and 6 run to the correct timings and Periods 7 and 8 are set to zero.

#### *Establishing Pedestrians on the Crossing*

- k) Insert a demand and confirm that when a pedestrian enters the crossing at the very end of the pedestrian green (Period 4) that the on-crossing detectors establish pedestrians on the crossing and extend Period 6 accordingly.
- l) Repeat as necessary to verify operation across the full width of the pedestrian waiting area.
- m) Insert a demand and confirm that when a pedestrian enters the crossing during the fixed all red (Period 5) that the on-crossing detectors establish pedestrians on the crossing and extend Period 6 accordingly.
- n) Repeat as necessary to verify operation across full width of the pedestrian waiting area.

#### *Slow Speed Pedestrians*

- o) Repeat (f) to (n) for slow moving pedestrians (approximately 0.5 metres/second).

(Note to ensure that pedestrians are safely established on the crossing it may be necessary to set the detector up so that pedestrians leaving the crossing cause Period 6 to hang on slightly.)

**APPENDIX H**

**MAINTENANCE INSPECTIONS AND OPERATIONAL CHECKS**

## H.1 Puffin Operational Check

Two procedures have been defined, one for kerbside and one for on-crossing detection.

## H.2 Annual Inspection

The annual inspection should include the operational check together with the following added requirements:

- a) if appropriate, the pedestrian detector set up should also be checked with the manufacturers' detector equipment/software;
- b) the operation of the detectors should be monitored by observing the detector input at the controller via the controller handset port to ensure all configured inputs remain operational in software;
- c) the controller fault log should be checked for any kerbside or on-crossing detector faults; and
- d) all current timings should be recorded.

It may also be necessary to clean the lenses of some types of above ground pedestrian detectors but manufacturers will advise on this.

Staff undertaking annual inspection of Puffin operation should be competent with appropriate accreditation through Sector 8 or other equivalent training and assessment.

This procedure should be integrated into the annual inspection.

## H.3 Initial Operational Check

If required, operational checks could be undertaken at other times if required, for example within one week of commissioning to verify operation and as part of the annual inspection.

### *Procedure for an Operational Check of Kerbside Detection*

The objective is to determine if the kerbside detection retains demands when pedestrians are present but cancels demands when pedestrian move out of the waiting area:

- a) Identify the limits of the pedestrian waiting area.
- b) Enter a pedestrian demand and remain in the centre of the pedestrian waiting area and verify the demand is held.
- c) Enter a pedestrian demand but move around the waiting area to verify the kerbside detector covers the full waiting area and holds the demand when a pedestrian is present in the waiting area.
- d) Enter a pedestrian demand and move out of the pedestrian waiting area and verify demand is cancelled within the time specified in the timings (this typically will be about two seconds).
- e) Repeat the above for each pedestrian waiting area.

If used, test the additional safety feature described on Page 16 by pressing the PB without activating the associated kerbside detector and verify the demand is not cancelled even when there is are no pedestrians in the pedestrian waiting area.

This procedure should be followed for each waiting area. If, as a result of the inspection procedure any one of the checks fails, then adjustments/repairs should be made by the relevant agency. After adjustment or repair then the operation should be rechecked as above.

### *Procedure for an Operational Check of On-crossing Detection*

The initial objective is to determine if the on-crossing detection correctly extends the all-red:

- a) Verify after the pedestrian green signal terminates and there are no pedestrians on the crossing that the fixed all-red (Period 5) runs to the correct time and then the controller then reverts immediately to traffic green. This also demonstrates that Period 6 runs zero seconds when there are no pedestrians on the crossing.
- b) Verify that the on-crossing detection is extending the variable all-red (Period 6) when pedestrians are on the crossing then stops extending shortly after pedestrians exit the footway.
- c) Verify if pedestrians remain on the crossing Period 6 runs to its maximum.
- d) Repeat the above but walk along the limits of the crossing area (the crossing studs).
- e) Repeat the above but at a much slower walking speed.

The second objective is to ensure that pedestrians are being established on the crossing and the all-red extended accordingly:

- a) At the end of the green pedestrian signal enter the crossing and cross at a reasonable speed, walking across the carriageway down the centre of the crossing. Verify the on-crossing detection picks up and establishes pedestrians on the crossing.
- b) Repeat the above but along each line of the studs.
- c) Repeat both the above but at a slower walking speed.

This procedure should be followed for each pedestrian crossing. If as a result of the inspection procedure any one of the checks fails, then adjustments/repairs should be made by the relevant agency. After adjustment or repair then the operation should be checked as above.

**APPENDIX I**

**EXAMPLE WORKSHEET FOR SCHOOL CHILDREN**

# PUFFINS SPOTTED IN DARLINGTON

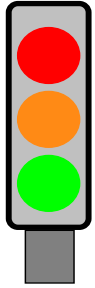

A new sort of crossing has been spotted on North Road, near St Paul's Terrace, it's called a *Puffin crossing*. It can help you cross a busy road and it looks a lot like a Pelican crossing. The traffic lights can stop the cars to let people cross to the other side.

## *How do you use a Puffin Crossing?*

### 1. STOP AND SEE IF IT IS SAFE TO CROSS

At the Puffin crossing we can see if it is safe to cross by looking at the green man and red man. There will be in a little box next to you at the Puffin crossing.

- A red man means you must not cross
- A green man means you can cross if it is safe

### 2. IF THERE IS A RED MAN SHOWING THEN PRESS THE BUTTON NEXT TO YOU AND WAIT

Press the button on the box with the red man in. A light will come on and stay lit until green man comes on.

### 3. WHEN YOU SEE THE GREEN MAN LIGHT UP, AND THE TRAFFIC HAS STOPPED, CROSS THE ROAD.

Once you have crossed, the red man will light up again and the traffic lights will change to green to let the cars go.

# It's Easy!

# Say Cheese!

There are special **cameras** on top of the traffic lights so the Puffin crossing knows when you have got to the other side of the road. It will only let the cars go when you have finished crossing.

The lights will not change if somebody presses the button to stop the cars and then runs off - the cameras can see them too!

## puffin wordsearch

Can you find these words?

*button red wait cross puffin traffic cars  
green safe lights cameras walk road stand*

w	m	b	i	t	s	g	b
c	a	m	e	r	a	s	m
r	a	l	c	a	x	m	o
o	g	r	k	f	y	s	a
s	r	o	s	f	n	t	d
s	e	w	a	i	t	a	n
r	e	d	f	c	o	n	p
m	n	f	e	r	k	d	t
r	u	l	i	g	h	t	s
p	b	u	t	t	o	n	u



.....joke.....

Q. Why did the Pelican think his friend was out of breath?

A. *Because he was Puffin'!!*



**newsflash... newsflash... newsflash**

Look out for Puffin crossings that will be appearing all over the country soon - complete with special cameraS

(Copyright Darlington Borough Council. Reproduced by permission.)